

Grizzly *Industrial, Inc.*®

MODEL H8191 3600 PSI DIESEL PRESSURE WASHER OWNER'S MANUAL



COPYRIGHT © AUGUST, 2007 BY GRIZZLY INDUSTRIAL, INC.
**WARNING: NO PORTION OF THIS MANUAL MAY BE REPRODUCED IN ANY SHAPE
OR FORM WITHOUT THE WRITTEN APPROVAL OF GRIZZLY INDUSTRIAL, INC.**

#LO9708 PRINTED IN CHINA



WARNING!

This manual provides critical safety instructions on the proper setup, operation, maintenance and service of this machine/equipment.

Failure to read, understand and follow the instructions given in this manual may result in serious personal injury, including amputation, electrocution or death.

The owner of this machine/equipment is solely responsible for its safe use. This responsibility includes but is not limited to proper installation in a safe environment, personnel training and usage authorization, proper inspection and maintenance, manual availability and comprehension, application of safety devices, blade/cutter integrity, and the usage of personal protective equipment.

The manufacturer will not be held liable for injury or property damage from negligence, improper training, machine modifications or misuse.



WARNING!

Some dust created by power sanding, sawing, grinding, drilling, and other construction activities contains chemicals known to the State of California to cause cancer, birth defects or other reproductive harm. Some examples of these chemicals are:

- **Lead from lead-based paints.**
- **Crystalline silica from bricks, cement and other masonry products.**
- **Arsenic and chromium from chemically-treated lumber.**

Your risk from these exposures varies, depending on how often you do this type of work. To reduce your exposure to these chemicals: Work in a well ventilated area, and work with approved safety equipment, such as those dust masks that are specially designed to filter out microscopic particles.

Table of Contents

INTRODUCTION.....	2
Foreword	2
Contact Info	2
General Identification	4
SECTION 1: SAFETY	5
Safety Instructions for Machinery	5
Additional Safety Instructions for Pressure Washers.....	7
SECTION 2: SETUP	8
Unpacking	8
Inventory.....	8
Assembly.....	9
SECTION 3: OPERATIONS	10
Connections and Controls.....	10
Break-In.....	11
Adjusting Pressure	11
Changing Nozzles	11
Applying Chemicals.....	12
Drawing Water from Standing Water Source.....	13
Spray Gun Lock	14
Starting.....	14
Shutdown Procedure.....	15
SECTION 4: ACCESSORIES	16
SECTION 5: MAINTENANCE	17
Schedule	17
General Maintenance	18
Engine Oil and Filter Service	18
Pump Oil Change.....	19
Air Filter Service.....	20
Fuel Filter Change.....	21
Troubleshooting.....	22
Pump Parts Breakdown	23
Engine Block Parts Breakdown.....	25
Engine Cylinder Head Parts Breakdown.....	26
Engine Piston and Crank Parts Breakdown.....	27
Engine Fuel Tank Parts Breakdown	28
Engine Lubrication/Speed Parts Breakdown	29
Engine Recoil Starter Parts Breakdown.....	30
Engine Air Filter, Muffler, and Fuel Pump Parts Breakdown	31
Engine Electric Start Parts Breakdown	32
Frame and Hardware Parts Breakdown.....	33
Machine Labels Breakdown	34
WARRANTY AND RETURNS	37

INTRODUCTION

Foreword

We are proud to offer the Model H8191 9HP 3600 PSI Diesel Pressure Washer. This machine is part of a growing Grizzly family of fine power tools. When used according to the guidelines set forth in this manual, you can expect years of trouble-free, enjoyable operation and proof of Grizzly's commitment to customer satisfaction.

The specifications, drawings, and photographs illustrated in this manual represent the Model H8191 when the manual was prepared. However, owing to Grizzly's policy of continuous improvement, changes may be made at any time with no obligation on the part of Grizzly.

For your convenience, we always keep current Grizzly manuals available on our website at **www.grizzly.com**. Any updates to your machine will be reflected in these manuals as soon as they are complete. Visit our site often to check for the latest updates to this manual!

Contact Info

If you have any comments regarding this manual, please write to us at the address below:

Grizzly Industrial, Inc.
c/o Technical Documentation Manager
P.O. Box 2069
Bellingham, WA 98227-2069
Email: manuals@grizzly.com

We stand behind our machines. If you have any service questions or parts requests, please call or write us at the location listed below.

Grizzly Industrial, Inc.
1203 Lycoming Mall Circle
Muncy, PA 17756
Phone: (570) 546-9663
Fax: (800) 438-5901
E-Mail: techsupport@grizzly.com
Web Site: <http://www.grizzly.com>





MACHINE DATA SHEET

Customer Service #: (570) 546-9663 • To Order Call: (800) 523-4777 • Fax #: (800) 438-5901

MODEL H8191 9 HP DIESEL 3600 PSI PRESSURE WASHER

Product Dimensions:

Machine Size 28"W x 40"D x 35¼"H
Machine Weight 214 lbs.

Motor:

Type Diesel Fueled Internal Combustion
Displacement 406cc
Horsepower 9 HP
Torque 15.5 ft. lbs.
Starter Hand-Pulled Rope and Electric Starter
Ignition Compressed Ignition
Recommended Oil Weight SAE 10W-30

Pump:

Speed 3400 RPM
Maximum Pressure 3600 PSI
Capacity 4 GPM @3400 RPM
Power Requirement 9 HP
Recommended Oil Weight SAE 30

Construction:

Cart Steel

Features:

- 34½" Spray Gun with Comfort Grip
- 5 Quick Change Spray Nozzles 0°, 15°, 25°, 40°, and a Low Pressure Soap/Chemical Nozzle
- Wheeled Cart for Added Maneuverability
- Electric Starter



General Identification

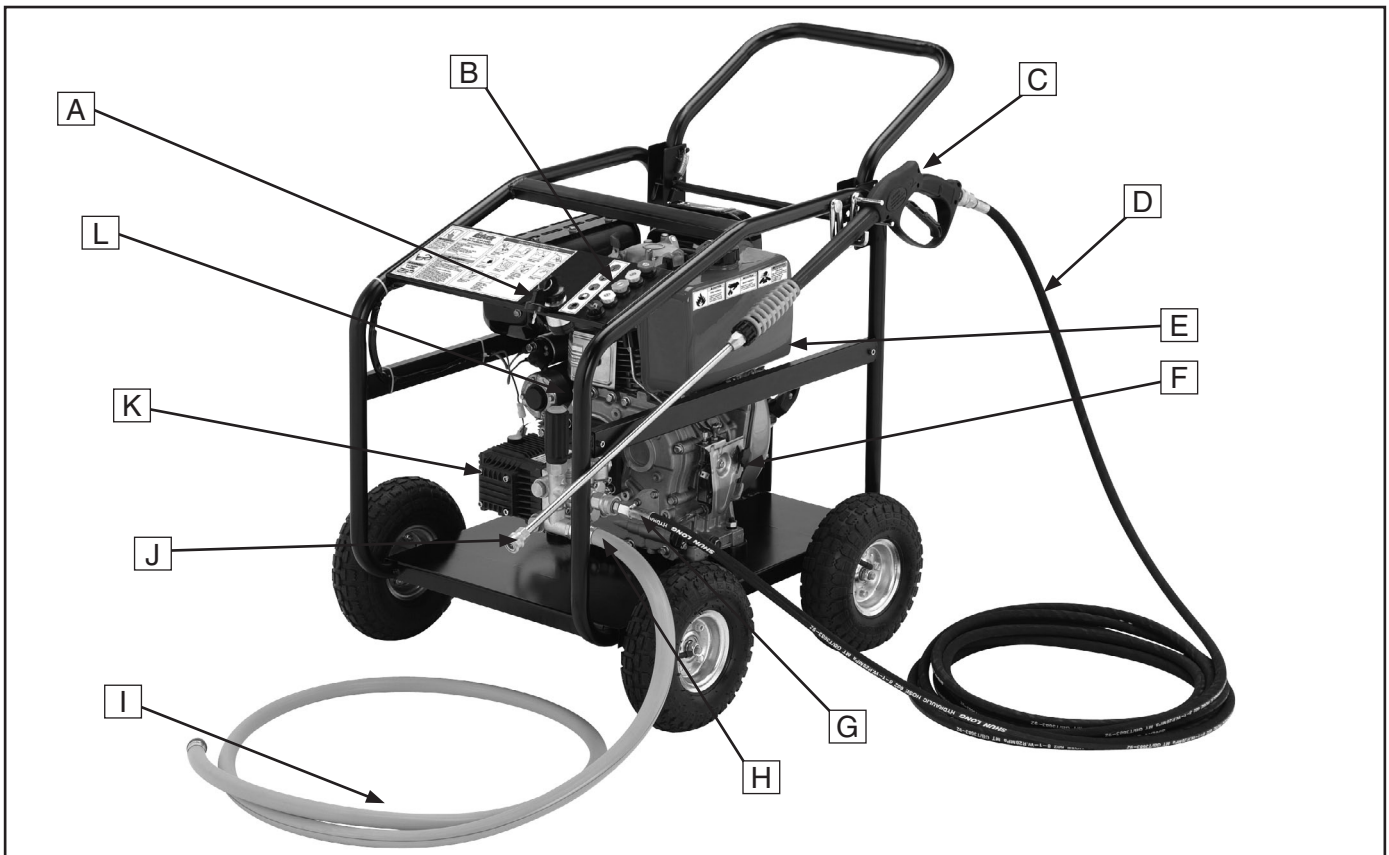

Figure 1. General component identification

- | | |
|---------------------------------|----------------------------|
| A. Electric Start Switch | G. Pump Output Port |
| B. Spray Gun Nozzles | H. Pump Input Port |
| C. Spray Gun | I. Input Hose |
| D. High Pressure Hose | J. Spray Gun Wand |
| E. Fuel Tank | K. Pump |
| F. Speed Control | L. Engine |



SECTION 1: SAFETY

WARNING

For Your Own Safety, Read Instruction Manual Before Operating this Machine

The purpose of safety symbols is to attract your attention to possible hazardous conditions. This manual uses a series of symbols and signal words intended to convey the level of importance of the safety messages. The progression of symbols is described below. Remember that safety messages by themselves do not eliminate danger and are not a substitute for proper accident prevention measures.



Indicates an imminently hazardous situation which, if not avoided, **WILL** result in death or serious injury.



Indicates a potentially hazardous situation which, if not avoided, **COULD** result in death or serious injury.



Indicates a potentially hazardous situation which, if not avoided, **MAY** result in minor or moderate injury. It may also be used to alert against unsafe practices.

NOTICE

This symbol is used to alert the user to useful information about proper operation of the machine.

WARNING

Safety Instructions for Machinery

- 1. READ THE ENTIRE MANUAL BEFORE STARTING MACHINERY.** Machinery presents serious injury hazards to untrained users.
- 2. ALWAYS USE ANSI APPROVED SAFETY GLASSES WHEN OPERATING MACHINERY.** Everyday eyeglasses only have impact resistant lenses—they are NOT safety glasses.
- 3. ALWAYS WEAR A NIOSH APPROVED RESPIRATOR WHEN OPERATING MACHINERY THAT PRODUCES DUST.** Wood dust can cause severe respiratory illnesses.
- 4. ALWAYS USE HEARING PROTECTION WHEN OPERATING MACHINERY.** Machinery noise can cause permanent hearing loss.
- 5. WEAR PROPER APPAREL. DO NOT** wear loose clothing, gloves, neckties, rings, or jewelry that can catch in moving parts. Wear protective hair covering to contain long hair and wear non-slip footwear.
- 6. NEVER OPERATE MACHINERY WHEN TIRED OR UNDER THE INFLUENCE OF DRUGS OR ALCOHOL.** Be mentally alert at all times when running machinery.



WARNING

Safety Instructions for Machinery

7. **ONLY ALLOW TRAINED AND PROPERLY SUPERVISED PERSONNEL TO OPERATE MACHINERY.** Make sure operation instructions are safe and clearly understood.
8. **KEEP CHILDREN AND VISITORS AWAY.** Keep all children and visitors a safe distance from the work area.
9. **MAKE WORKSHOP CHILDPROOF.** Use padlocks, master switches, and remove start switch keys.
10. **NEVER LEAVE WHEN MACHINE IS RUNNING.** Turn power **OFF** and allow all moving parts to come to a complete stop before leaving machine unattended.
11. **DO NOT USE IN DANGEROUS ENVIRONMENTS.** DO NOT use machinery in damp, wet locations, or where any flammable or noxious fumes may exist.
12. **KEEP WORK AREA CLEAN AND WELL LIGHTED.** Clutter and dark shadows may cause accidents.
13. **USE A GROUNDED EXTENSION CORD RATED FOR THE MACHINE AMPERAGE.** Grounded cords minimize shock hazards. Undersized cords create excessive heat. Always replace damaged extension cords.
14. **ALWAYS DISCONNECT FROM POWER SOURCE BEFORE SERVICING MACHINERY.** Make sure switch is in OFF position before reconnecting.
15. **MAINTAIN MACHINERY WITH CARE.** Keep blades sharp and clean for best and safest performance. Follow instructions for lubricating and changing accessories.
16. **MAKE SURE GUARDS ARE IN PLACE AND WORK CORRECTLY BEFORE USING MACHINERY.**
17. **REMOVE ADJUSTING KEYS AND WRENCHES.** Make a habit of checking for keys and adjusting wrenches before turning machinery **ON**.
18. **CHECK FOR DAMAGED PARTS BEFORE USING MACHINERY.** Check for binding or misaligned parts, broken parts, loose bolts, and any other conditions that may impair machine operation. Repair or replace damaged parts before operation.
19. **USE RECOMMENDED ACCESSORIES.** Refer to the instruction manual for recommended accessories. Improper accessories increase risk of injury.
20. **DO NOT FORCE MACHINERY.** Work at the speed for which the machine or accessory was designed.
21. **SECURE WORKPIECE.** Use clamps or a vise to hold the workpiece when practical. A secured workpiece protects your hands and frees both hands to operate the machine.
22. **DO NOT OVERREACH.** Maintain stability and balance at all times.
23. **MANY MACHINES CAN EJECT WORKPIECES TOWARD OPERATOR.** Know and avoid conditions that cause the workpiece to "kickback."
24. **ALWAYS LOCK MOBILE BASES (IF USED) BEFORE OPERATING MACHINERY.**
25. **CERTAIN DUST MAY BE HAZARDOUS** to the respiratory systems of people and animals, especially fine dust. Be aware of the type of dust you are exposed to and always wear a respirator designed to filter that type of dust.



WARNING

Additional Safety Instructions for Pressure Washers

- 1. FLUID INJECTION.** This machine operates at fluid pressures and velocities high enough to penetrate human and animal flesh. Should such an injury occur, it may be a surgical emergency. **DO NOT** treat fluid injection as a normal cut, instead, see a physician immediately.
- 2. ADEQUATE VENTILATION.** During operation this machine produces carbon monoxide, which is a poisonous gas. Make sure the work area is adequately ventilated. Never operate this machine indoors.
- 3. COOLING ENGINE.** Motor parts get hot during operation. Allow to cool before placing hands near motor, adding fuel, or performing any service or maintenance.
- 4. FUEL SPILLS.** Fuel exposed to hot engine components may ignite. Thoroughly clean all fuel spills before starting.
- 5. ELECTRICAL OVERSPRAY HAZARD.** Spraying water near electrical outlets, switches, or objects connected to an electrical circuit, could result in a fatal electric shock.
- 6. CHANGING NOZZLES.** Be sure to release water pressure before changing nozzles, or performing any service or maintenance, to reduce the risk of fluid injection injury.
- 7. APPROVED FLUIDS.** Some cleaning fluids could cause injury to skin, eyes, or lungs. Use only cleaning fluids approved for high pressure washers and follow the manufacturer's recommendations. Never spray any corrosive chemicals, poisons, insecticides, or flammable solvents with this machine.
- 8. HOLDING SPRAY GUN.** The reactive force of the spray will cause the gun to move, and could cause the operator to fall or misdirect the spray. Always stand in a stable position, grip the gun firmly with both hands, and do not overreach. Use extreme caution on roofs and ladders and always wear appropriate harnesses and safety equipment.
- 9. SLIPPING HAZARDS.** The use of pressure washers can create puddles and other slippery surfaces. Use extreme caution on these surfaces to reduce the risk of a fall.

WARNING

Like all machinery there is potential danger when operating this machine. Accidents are frequently caused by lack of familiarity or failure to pay attention. Use this machine with respect and caution to lessen the possibility of operator injury. If normal safety precautions are overlooked or ignored, serious personal injury may occur.

CAUTION

No list of safety guidelines can be complete. Every shop environment is different. Always consider safety first, as it applies to your individual working conditions. Use this and other machinery with caution and respect. Failure to do so could result in serious personal injury, damage to equipment, or poor work results.



SECTION 2: SETUP

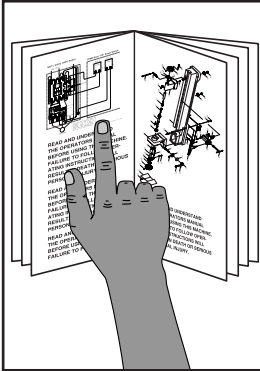

! WARNING
This machine presents serious injury hazards to untrained users. Read through this entire manual to become familiar with the controls and operations before starting the machine!

Unpacking

Your machine was carefully packaged for safe transportation. Remove the packaging materials from around your machine and inspect it. If you discover the machine is damaged, *please immediately call Customer Service at (570) 546-9663 for advice.*

Save the containers and all packing materials for possible inspection by the carrier or its agent. *Otherwise, filing a freight claim can be difficult.*

When you are completely satisfied with the condition of your shipment, inventory the contents.

Inventory

The following is a description of the main components shipped with your machine. Lay the components out to inventory them.

Note: *If you can't find an item on this list, check the mounting location on the machine or examine the packaging materials carefully. Occasionally we pre-install certain components for shipping purposes.*

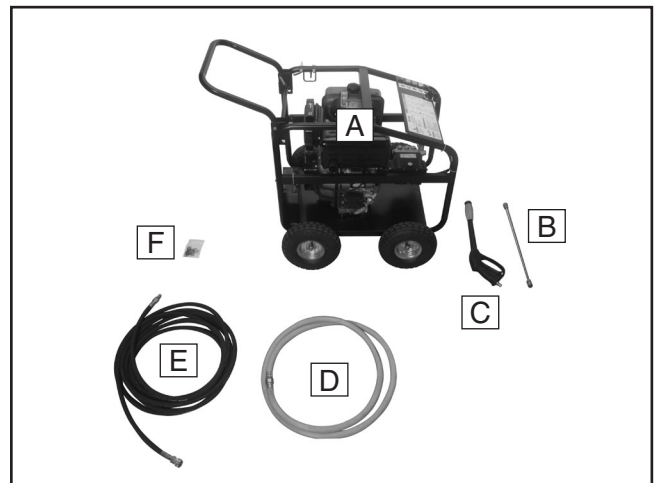

Figure 2. Model H8191 inventory

H8191 Inventory (Figure 2)	Qty
A. Pressure Washer.....	1
B. Spray Gun Wand.....	1
C. Spray Gun.....	1
D. Input Hose.....	1
E. High Pressure Hose.....	1
F. Accessory Kit.....	1



Assembly

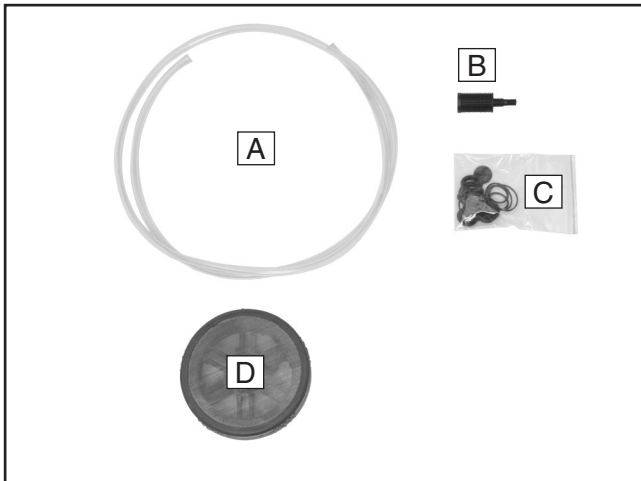

Figure 3. Model H8191 accessory inventory.

H8191 Accessory Inventory (Figure 3)	Qty
A. Chemical Hose	1
B. Chemical Filter	1
C. O-Ring Seal Kit	1
D. Input Hose Filter	1
E. Hose Adapter Male-to-Male (not shown) ..	1

Refer to **Figure 1** on **Page 4** for identification of components in the following steps.

To assemble the H8191:

1. Thread the spray gun wand into the spray gun and tighten securely.
2. Connect the male end of the high pressure hose to the pump output port.
3. Connect the high pressure hose quick coupler to the spray gun.
4. Connect the female end of the input hose onto the pump input port.
5. Connect the other end of the input hose to a spigot providing at least 5 GPM, or to the input hose filter, if drawing from a standing water source.

Note: Depending on the spigot fitting type, you may need to use the provided male-to-male input hose adapter to connect the pressure washer to this type of water source.



SECTION 3: OPERATIONS

Connections and Controls

- A. Water Pressure Adjustment Knob
- B. Chemical Injection Port
- C. Pump Output Port
- D. Pump Input Port

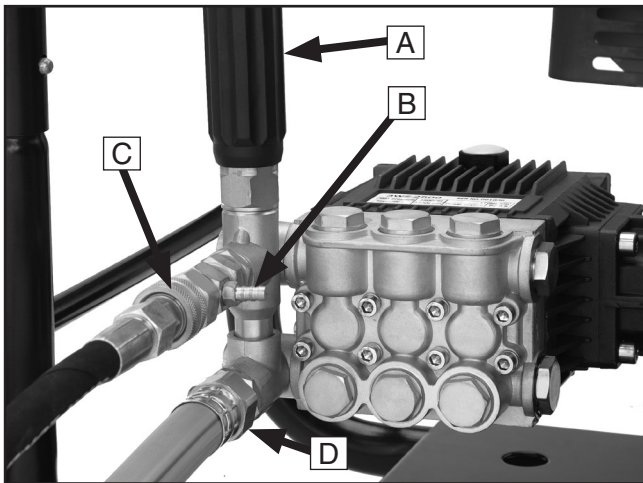

Figure 4. Pump Controls.

- E. Fuel Valve
- F. Speed Control Lever
- G. Compression Release Lever
- H. Pull-Start Handle

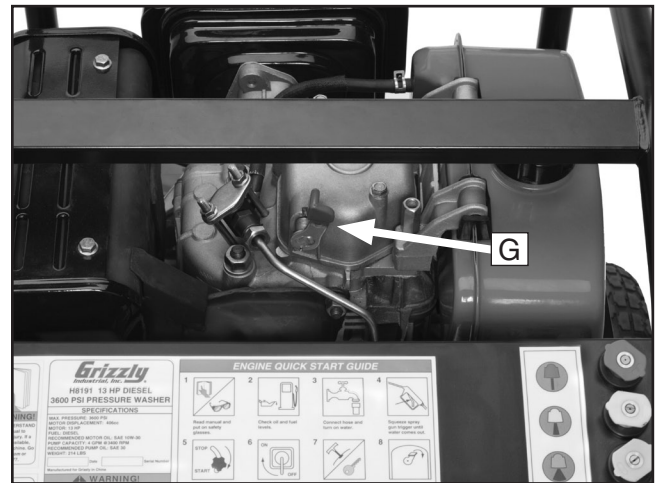

Figure 6. Additional motor controls.

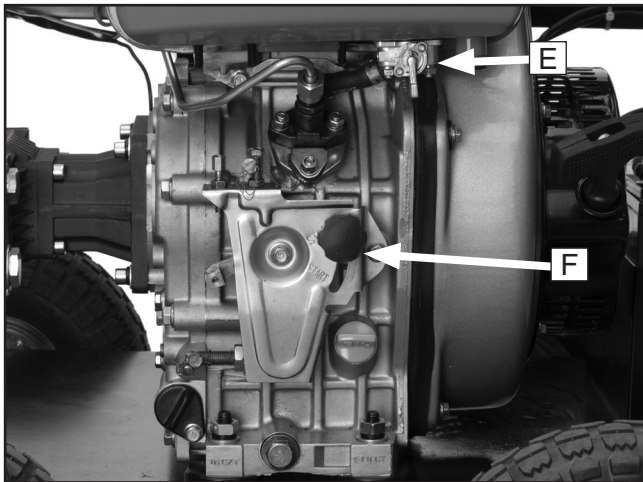

Figure 5. Motor controls.

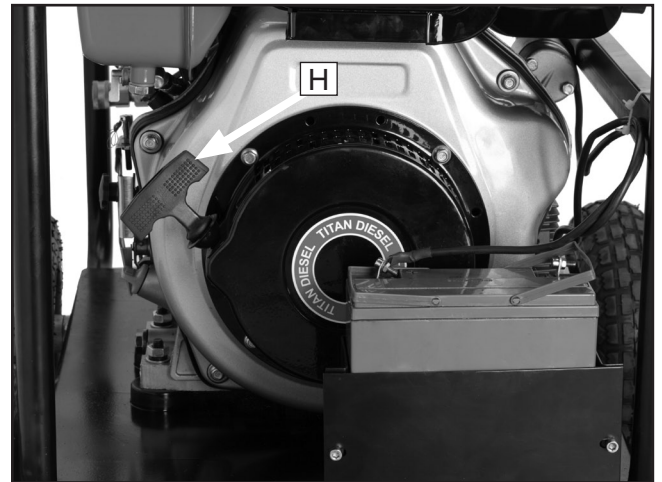

Figure 7. Pull-start handle location.



Break-In

The first 20 hours of operation is considered the break-in period. Be sure to follow the maintenance schedule on **Page 16** after 20 hours of use.

NOTICE

Failure to follow the break-in maintenance schedule can reduce the lifespan of the machine and negatively impact performance.

Adjusting Pressure

! WARNING

DO NOT attempt to increase the maximum pump pressure by modifying controls or otherwise altering the machine. A higher pressure setting than the factory set maximum pressure may damage the pump or cause components to fail, resulting in serious personal injury.

The pressure setting on the Model H8191 was preset at the factory to achieve optimum pressure for general purpose cleaning.

To adjust the pressure:

- BACK AWAY FROM THE SURFACE TO BE CLEANED. Moving further away reduces the pressure on the workpiece.
- SELECT A DIFFERENT NOZZLE. Nozzles with a wider angled spray deliver a less powerful stream.
- ADJUST THE PRESSURE REGULATOR ON THE PUMP. Turn the water pressure adjustment knob counterclockwise to lower the pressure (**Figure 8**). Once you have finished using your pressure washer, return the regulator to its original position by turning it clockwise.

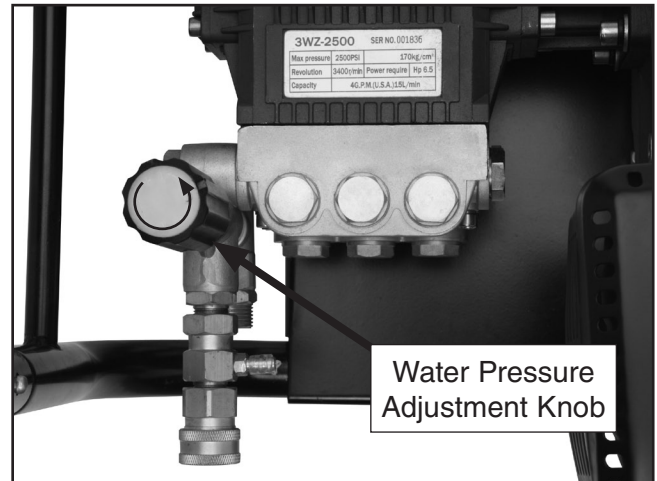

Figure 8. Water pressure adjustment knob.

- REDUCE ENGINE SPEED. Slowing the engine will reduce the pressure created by the pump.

NOTICE

Engine speed should always be set high enough to handle the load of the pump. If the engine speed is too low, the motor may bog or stop when the spray gun trigger is pulled and the pump is activated. Operating the engine speed at such a setting can cause excessive engine wear and premature engine failure.

Changing Nozzles

The Model H8191 pressure washer is equipped with five spray nozzles housed in receptacles on the front panel. Each nozzle is color coded and delivers a specific spray pattern for a particular cleaning purpose. The 0°, 15°, 25°, and 40° nozzles are high pressure nozzles; the chemical nozzle is a low pressure nozzle.



To change nozzles:

1. FOLLOW THE SHUTDOWN PROCEDURE ON **PAGE 15!**
2. Pull back the quick connect coupler on the end of the spray gun wand and remove the current nozzle.
3. Select a nozzle, pull back the quick connect coupler and insert the nozzle, as shown in **Figure 9**.



Figure 9. Inserting a nozzle.

4. Release the quick connect coupler, then twist and pull the nozzle to make sure it is secure in the coupler.

!WARNING

Always double-check coupler connections on all fittings. Improperly connected fittings can blow apart under pressure, causing severe personal injury or equipment damage.

NOTICE

Always try a nozzle on a small test area or piece of test material to determine if it is the correct nozzle for the task. Some nozzles provide so much pressure they can destroy even sturdy materials.

Nozzles

0° Red Nozzle

This nozzle delivers an extremely powerful pinpoint stream that covers a very small cleaning area.

15° Yellow Nozzle

This nozzle delivers a powerful 15° spray pattern for intense cleaning of small areas.

25° Green Nozzle

This nozzle delivers a 25° spray pattern for intense cleaning of larger areas.

40° White Nozzle

This nozzle delivers a 40° spray pattern and a less powerful stream of water. It covers a wide area of cleaning.

Chemical Black Nozzle

This nozzle is used to apply chemicals or cleaning solutions. It has the least powerful stream.

Applying Chemicals

!WARNING

Use only household detergents, cleaners, and degreasers recommended for use in pressure washers. NEVER use toxic or corrosive chemicals, acids, poisons, insecticides, or flammable solvents such as gasoline or kerosene with your pressure washer. Failure to follow this warning could result in machine failure, significant property damage, severe personal injury, or death.

!CAUTION

Applying chemicals or cleaning solvents is a low pressure operation. Use only the chemical nozzle to apply chemicals or solvents.



NOTICE

Chemicals left in the pressure washer can damage the pump and void the warranty. Always rinse the unit thoroughly by running clean water through the chemical hose after using chemicals or cleaning solvents.

To apply chemicals:

1. Push the chemical hose onto the barbed fitting located near the pump output port, as shown in **Figure 10**.

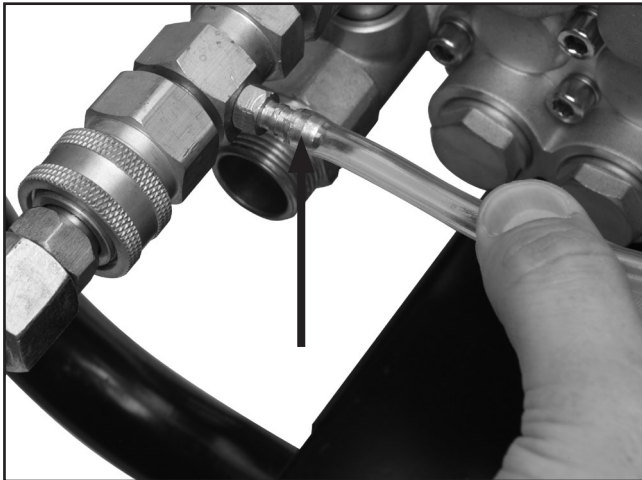

Figure 10. Chemical hose attached to barbed fitting.

2. Push the other end of the chemical hose onto the chemical hose filter (**Figure 11**), and fully submerge in a container holding the chemical or cleaning solution.



Figure 11. Chemical hose filter attached.

3. Connect the low pressure chemical nozzle to the spray gun as described on **Page 12**.
4. After using chemicals or cleaning solutions, draw clean water through the chemical hose and pressure washer to rinse the internal components.

Drawing Water from Standing Water Source

To draw water from a standing source:

1. Attach the supplied input hose filter to the input hose and place the input hose filter in the standing water source.

Note: Be sure the water source is free from debris that could clog the filter and cause a loss of water flow.

2. Prime the pump by pouring water into the other end of the input hose (the end without the filter) while the filter end is submerged in the water source. Without spilling water out of the hose, connect the input hose to the input port on the pump.

Note: Be sure the water source is large enough to provide 5 GPM of flow for the duration of the pressure washer operation.

NOTICE

If the pump is not able to provide pressurized water when drawing from a standing water source, shutdown the pressure washer immediately and re-attempt to prime the pump. Failure to follow this instruction can damage the pump and void the warranty.



Spray Gun Lock

The spray gun has a lockout lever that can be engaged to prevent accidental discharge. This feature is especially useful when climbing up a ladder or doing any work that might accidentally discharge the spray gun. To engage the lockout lever, simply flip it away from the trigger and clip it into the lockout lever groove in the handle (**Figure 12**). To release the lever, reverse this procedure (**Figure 13**).



Figure 12. Spray gun trigger locked.



Figure 13. Spray gun trigger unlocked.

Starting

!WARNING

Operation of this equipment has the potential to propel debris into the air, which can cause eye injury. Always wear safety glasses or goggles when operating equipment. Everyday glasses or reading glasses only have impact resistant lenses, they are not safety glasses. Be certain the safety glasses you wear meet the appropriate standards of the American National Standards Institute (ANSI).

To start the pressure washer:

1. Check the engine and pump oil level and fuel level (refer to the **MAINTENANCE** section beginning on **Page 17** for locations). Add engine oil (SAE 10W-30) and fuel (diesel) if necessary.
2. Securely fasten one end of the provided input hose to a threaded hose spigot. Securely fasten the other end of the input hose to the pump input port.

Note: When drawing water from a standing source, follow the standing source instructions on **Page 13**. When drawing water from a spigot, you may need to use the provided male-to-male hose adapter.

3. Make sure the spray gun is securely connected to the high pressure hose, and that the high pressure hose is securely connected to the pump output port.
4. Attach the appropriate nozzle to the quick coupler at the end of the spray gun wand, and turn on the water supply at the spigot.

NOTICE

Never allow the motor to run without a water source connected to the pump. Failure to follow this instruction will damage the pump and void the warranty.



5. Switch the motor to the **START** position by loosening the speed control lever locking bolt, moving the mechanism downward, and retightening the bolt next to the word "START" (**Figure 5, Page 10**).
6. Open the fuel valve by rotating the lever clockwise until it is vertical (**Figure 14**).

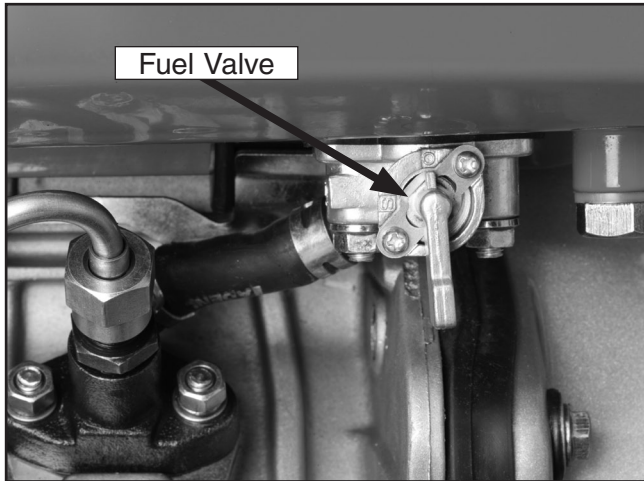

Figure 14. Fuel valve in open position.

7. Squeeze the spray gun trigger until a steady stream of water comes out, then release.
8. Unlock the compression release lever by pulling the start rope until resistance is felt.
9. Push the compression release lever down until it latches.
10. Pull the start rope handle with forceful, but even pressure, or turn the electric start switch to start the motor.

⚠ CAUTION

When pull-starting, pull the start rope slowly until resistance is felt, then pull with forceful, even pressure. Rapidly jerking the start rope can cause it to forcefully recoil, potentially causing hand or arm injury.

11. Allow the motor to run for at least two minutes to achieve normal operating temperature, then set the speed control lever to the desired speed.

12. Pull the trigger on the spray gun to release pressurized water and begin spraying.

Note: *If the motor does not start after several pulls of the start rope or brief turns of the start switch, repeat the starting instructions from **Step 7**. If you are still unable to start the motor, refer to **Troubleshooting** on **Page 22**.*

NOTICE

Never allow the motor to run for more than five minutes without pulling the trigger on the spray gun to release water. Failure to follow this instruction can damage the pump and void the warranty.

Shutdown Procedure

To shut down the pressure washer:

1. Release the spray gun trigger and return the spray gun to the bracket on the washer handle.
2. Allow the motor to run without pulling the spray gun trigger for 4 minutes.
3. Switch the motor to the **STOP** position by loosening the speed control lever locking bolt, moving the mechanism upward, and retightening the bolt next to the word "STOP" (**Figure 5**).
4. Close the fuel valve by rotating the lever counterclockwise until it is horizontal.
5. Shut off the water at the spigot, or remove the input line from the water if drawing from a standing source. Purge the pressure from the system by pulling the spray gun trigger.

NOTICE

To reduce the risk of damaging engine components, DO NOT stop the engine abruptly when it is running under load. NEVER attempt to stop the motor with the compression release lever.



SECTION 4: ACCESSORIES

H8118—Spot Sandblaster

This spot sandblaster is the quickest, cleanest way to remove rust spots, peeling paint, or surface blemishes without disturbing the surrounding area. Supplied with 4 nozzles that allow you to spot blast inside corners, outside corners, edges, and flat areas for perfect surface prep.



Figure 15. Model H8118 Spot Sandblaster.

G7142—Long Rubber Gloves

Industrial strength rubber gloves with 11" cuffs protect from finger tip to elbow. Positive grip on hands and fingers. Alkali and acid resistant.



Figure 16. Model G7142 Sandblasting Gloves.

G9927 and H3143—Wax Buffer

Wax the car in a jiffy with this buffer/polisher system. The pad duplicates hand polishing with a random orbit rotation. Kit includes a wax application bonnet and a terrycloth polishing bonnet. Safe for all types of finishes, gives a beautiful swirl free result.



Figure 17. Models G9927 and H3143 Wax Buffers.

H3265—24" Blow Gun

Get into hard-to-reach areas with this 24" long Blow Gun. Includes rubber tip. 1/4" female NPT.

H3261—5 pc. Air Blow Kit

This chrome plated, brass body Air Blow Gun includes five different tips for all normal air cleaning jobs. 1/4" NPT air inlet.

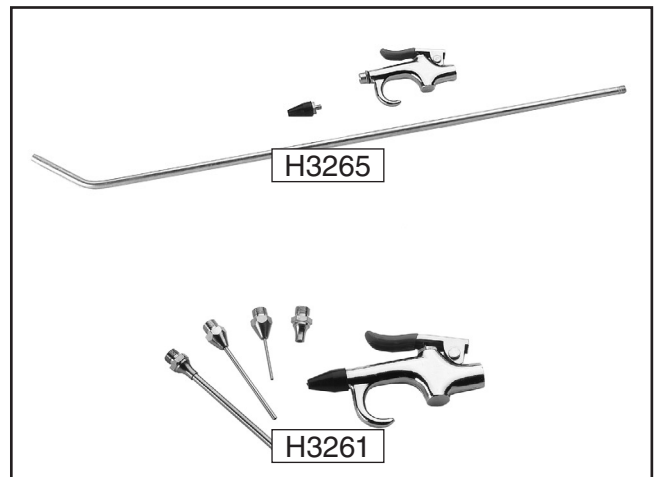

Figure 18. Model H3265 and H3261 air tools.

Call 1-800-523-4777 To Order



SECTION 5: MAINTENANCE

⚠️ WARNING

Always release water pressure and allow engine to cool before performing any service or maintenance. Failure to follow this warning can result in severe burns or fluid injection injuries.

NOTICE

Operating machinery in harsh conditions may require more frequent maintenance. The maintenance schedule below is a guideline for general use. If you operate your machine in extremely hot, cold, or dusty conditions, change oils and clean or replace filters with increased frequency.

Schedule

For optimum performance from your machine, follow this maintenance schedule and refer to any specific instructions given in this section.

<i>Interval</i>	Daily	Every 20 hours or 1 month	Every 100 hours or 3 months	Every 500 hours or 6 months	Every 1000 hours or 12 months
Check and tighten bolts	X				
Check for worn or damaged wires	X				
Check for oil/fuel leaks	X				
Check engine oil	X				
Change engine oil		X (First Time Break In)	X		
Clean engine oil filter		X (First Time Break In)	X		
Replace engine oil filter					X
Check pump oil	X				
Change pump oil		X (First Time Break In)	X	X	
Clean outer air filter		X			
Clean filter core		X			
Replace filter core				X	
Clean fuel tank		X			
Clean fuel filter				X	
Replace fuel filter					X

Figure 19. Maintenance schedule



General Maintenance

Before each use, perform the following general maintenance tasks:

1. Check the engine oil and fuel level
2. Check the engine for cracked fuel lines, loose bolts, and any other excessively worn or damaged parts. Repair or replace worn or damaged parts as necessary. Tighten any loose bolts.
3. Check the high pressure hose for leaks. Replace if necessary.
4. Inspect the spray gun and nozzles for clogged debris or damage. Clean any debris with a garden hose and replace any damaged parts.
5. Inspect the chemical injection hose and filter for clogged debris or damage. Clean any debris with a garden hose and replace any damaged parts.

Engine Oil and Filter Service

Replace the engine oil and clean the oil filter once after the first 20 hours, and then regularly after every 100 hours or 3 months (more frequently in harsh conditions).

To change the engine oil:

1. FOLLOW SHUTDOWN PROCEDURE AND ALLOW ENGINE TO COOL!
2. Loosen the dipstick/oil cap.
3. Remove the drain plug and drain plug gasket on the side of the engine (**Figure 20**) and allow oil to drain through the hole in the frame into a catch basin.

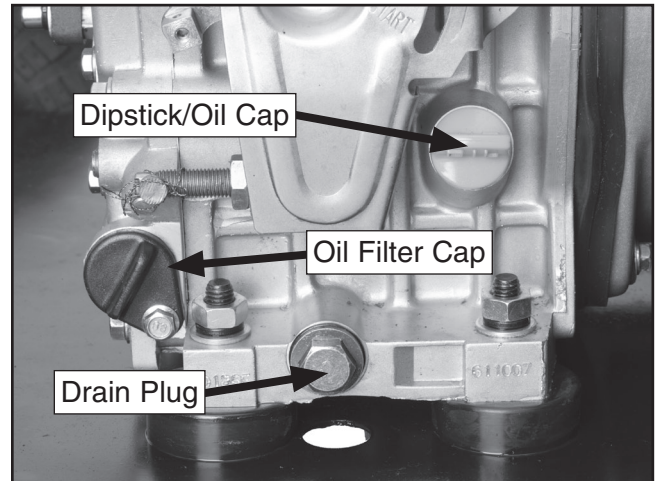

Figure 20. Components for oil and filter service.

4. Drain all oil and reinstall the drain plug and drain plug gasket.
5. Remove the bolt securing the oil filter cap (**Figure 20**).
6. Carefully draw out the oil filter cap and oil filter by hand or with needle nosed pliers.
7. Wipe away any particulate material collected in the filter screen with a clean, lint-free cloth, or with a soft bristled brush. Use mineral spirits to remove stubborn deposits.
8. Reinstall the filter screen and securely fasten the oil filter cap bolt.



- Remove the dipstick/oil cap and fill with an SAE 10W-30 motor oil rated for diesel engines. Check the level on the dipstick frequently until full (**Figure 21**). Avoid over filling or seals may be damaged.

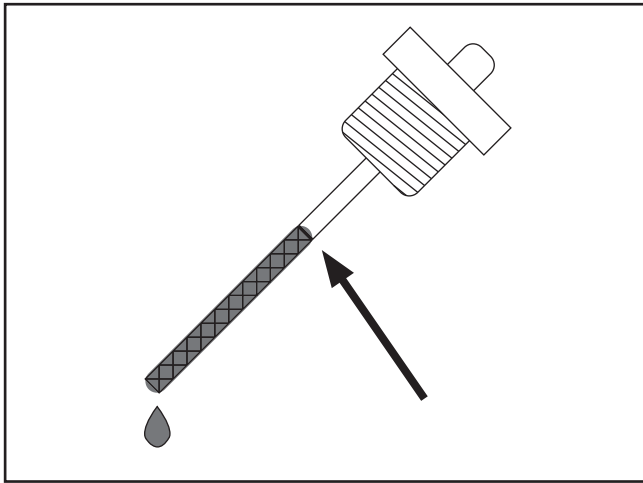

Figure 21. Correct engine oil level on the dipstick.

- Tighten the dipstick/oil cap.
- Dispose of the used oil in accordance with local regulations.

Pump Oil Change

Replace the pump oil once after 20 hours, and then regularly every 100 hours or 3 months.

To change the pump oil:

- FOLLOW SHUTDOWN PROCEDURE AND ALLOW ENGINE TO COOL!
- Loosen the oil cap (**Figure 22**).
- Place a container under the oil drain plug (**Figure 22**).

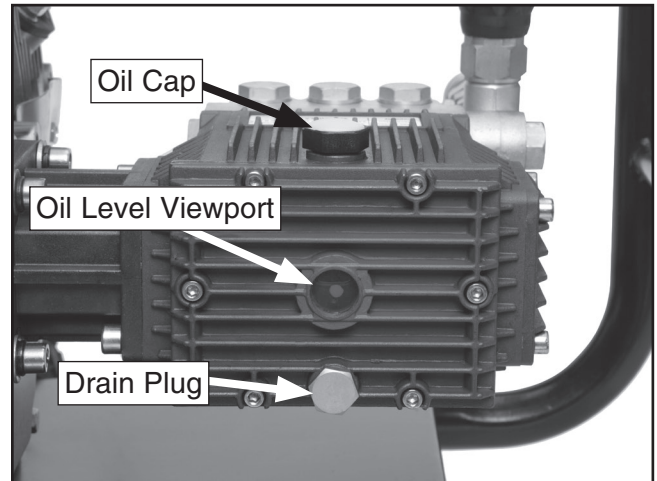

Figure 22. Pump oil cap and drain plug.

- Remove the oil drain plug and drain plug gasket.
- After all the oil has drained, reinstall and tighten the oil drain plug with drain plug gasket.
- Remove the oil cap and fill with SAE 30 oil. Add oil slowly and check the level frequently. The pump is full when oil is just past the red dot, covering the lower $\frac{2}{3}$ of the viewing port (**Figure 23**). Do not overfill.

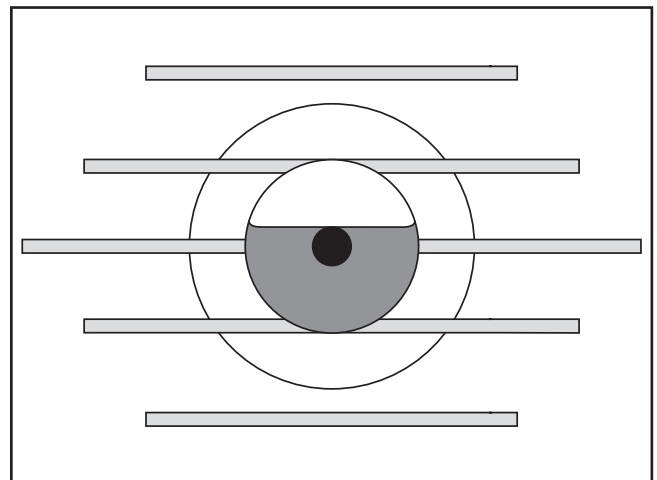

Figure 23. Correct pump oil level in the viewport.

- Reinstall the oil cap and tighten securely.
- Dispose of the used oil in accordance with local regulations.



Air Filter Service

Clean the outer air filter element after every 20 hours or 1 month (more frequently in harsh conditions).

To clean the outer air filter element:

1. FOLLOW SHUTDOWN PROCEDURE AND ALLOW ENGINE TO COOL!
2. Remove the air filter cover by first removing the air filter cover wing nut.
3. Remove the wing nut and washer holding the air filter in place, and remove the air filter assembly (**Figure 24**).



Figure 24. Removing the air filter.

4. Remove the outer foam air filter element from the filter core.
5. Clean the outer element thoroughly with mineral spirits and allow to dry.
6. Saturate the outer element with fresh motor oil, then squeeze with a cloth to remove excess oil.
7. Replace the outer air filter element, then replace the air filter assembly, filter wing nut, filter cover, and filter cover wing nut.

Note: To clean the air filter core, *DO NOT* use solvent or any other cleaning solution. Instead, use a soft brush to remove any particulate build-up.



Fuel Filter Change

Refer to the part breakdown on **Page 27** for identification of components in the following steps.

To change the fuel filter:

1. FOLLOW SHUTDOWN PROCEDURE AND ALLOW ENGINE TO COOL!
1. Drain the fuel tank by removing the fuel tank drain plug (**Figure 25**). Use a funnel and certified fuel container to capture the fuel as it drains.

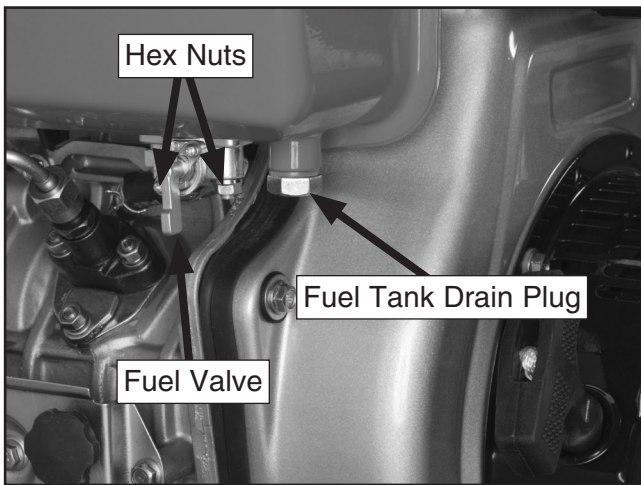

Figure 25. Fuel tank drain plug and fuel valve.

2. Remove the two hex nuts shown in **Figure 25**. These hex nuts hold both the fuel valve and the fuel filter in place.
3. Remove the fuel tank cap and extract the fuel filter through the top of the tank as shown in **Figure 26**.

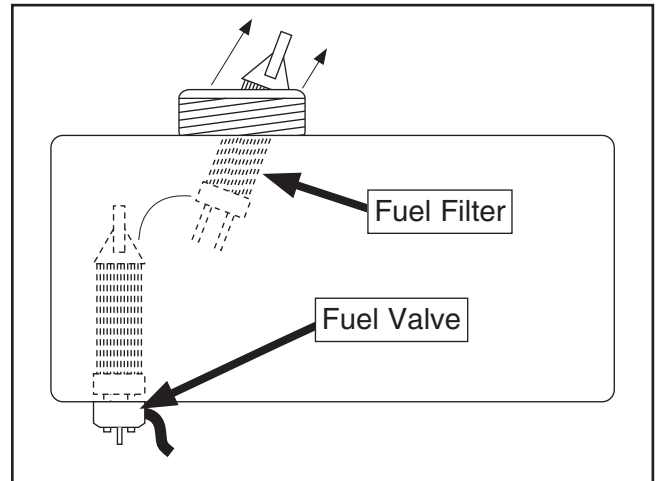

Figure 26. Removing the fuel filter.

4. Insert a new filter, making sure the gasket at the base of the fuel filter and the gasket at the base of the fuel valve are in place.
5. Fasten the fuel valve nuts securely.
6. Fasten the fuel tank drain plug securely.

Note: If you have difficulty removing the fuel filter, you may find it easier with the fuel tank removed entirely. To do this, refer to the parts breakdown on **Page 27**, remove the upper and lower fuel lines, and remove the upper tank bracket. Once the tank is removed, the fuel filter can be removed and replaced more easily. Be sure to reattach and securely fasten any fuel lines or brackets you remove.



Troubleshooting

Symptom	Possible Cause	Solution
Engine won't start.	<ol style="list-style-type: none"> 1. No fuel. 2. Cold weather has made fuel and oil overly adhesive. 3. Fuel valve is closed. 4. Air filter is clogged. 5. Water pressure has built up in the pump. 6. Internal engine components have failed. 	<ol style="list-style-type: none"> 1. Add fuel. 2. Move the machine into a warm area and allow the engine block to warm up before returning to work area to start. 3. Open fuel valve. 4. Clean air filter. 5. Release water pressure by squeezing spray gun trigger. 6. Refer to engine manual or see a qualified technician for repair.
Engine starts, but runs poorly.	<ol style="list-style-type: none"> 1. The fuel filter or fuel line is clogged. 2. The fuel valve is partially closed. 3. Low quality or contaminated fuel. 4. Air filter is dirty. 5. Engine speed is too slow. 6. Internal engine components are worn or have failed. 	<ol style="list-style-type: none"> 1. Clean the fuel filter or clear the fuel lines. 2. Fully open the fuel valve. 3. Replace with a clean, quality diesel fuel. 4. Clean air filter. 5. Increase throttle setting. 6. Refer to a qualified technician.
No, or low, water pressure.	<ol style="list-style-type: none"> 1. Low water supply. 2. Low pressure nozzle attached. 3. Leak at high pressure hose fitting. 4. Input hose filter screen clogged. 5. Engine is not in high throttle position. 6. High pressure hose is too long. 7. Engine or pump components are worn or have failed. 	<ol style="list-style-type: none"> 1. Water supply must flow at least 5 GPM. 2. Attach a higher pressure nozzle. 3. Tighten or replace fitting as necessary. 4. Remove and clean filter. 5. Increase engine speed with throttle lever. 6. Use high pressure hose under 100 ft. 7. Refer a qualified technician for repair.
Will not draw chemicals.	<ol style="list-style-type: none"> 1. Spray gun does not have low pressure nozzle attached. 2. Chemical filter clogged. 3. Chemical hose and filter not fully submerged in chemical. 4. Chemical is too thick. 	<ol style="list-style-type: none"> 1. Attach low pressure nozzle. 2. Clean filter. 3. Be sure chemical hose and filter stay fully submerged in chemical. 4. Dilute chemical. Chemicals should be the consistency of water.



Pump Parts Breakdown

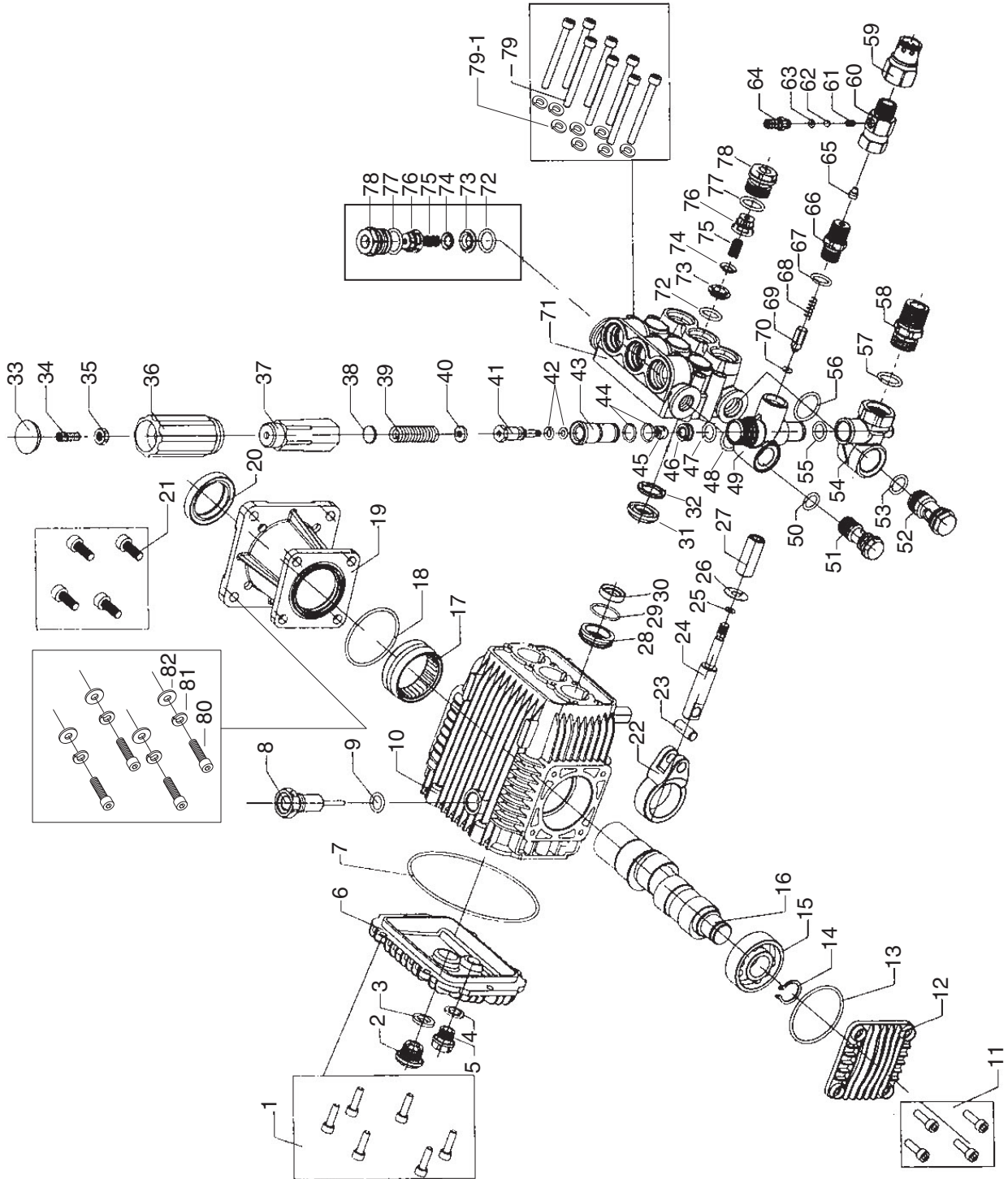

Pump Parts List

REF PART #	DESCRIPTION
1	PSB20M CAP SCREW M5-.8 X 14
2	PH81910002 OIL GAUGE
3	PH81910003 OIL GAUGE CASKET
4	PH81910004 DRAINPLUG GASKET
5	PH81910005 DRAINPLUG
6	PH81910006 CRANK CASE COVER
7	PH81910007 CRANK CASE COVER GASKET
8	PH81910008 OIL INLET PLUG
9	PH81910009 OIL INLET PLUG GASKET
10	PH81910010 CRANK CASE
11	PSB74M CAP SCREW M6-1 X 18
12	PH81910012 CRANK SHAFT COVER
13	PH81910013 BEARING COVER GASKET
14	PH81910014 BEARING CLIP
15	PH81910015 BALL BEARING
16	PH81910016 CRANKSHAFT
17	PH81910017 NEEDLE ROLLER BEARING
18	PH81910018 BEARING COVER GASKET
19	PH81910019 FLANGE
20	PH81910020 FLANGE OIL SEAL
21	PH81910021 CAP SCREW M8-1.25 X 24
22	PH81910022 CONNECTING ROD
23	PH81910023 PLUNGER PIN
24	PH81910024 PLUNGER ROD
25	PH81910025 PLUNGER ROD GASKET
26	PH81910026 WATER CHECKING FLAKE
27	PH81910027 CERAMIC PLUNGER
28	PH81910028 LOCATING RING
29	PH81910029 LOCATING RING GASKET
30	PH81910030 LOCATING RING WATER SEAL
31	PH81910031 U-PACKING SEAL
32	PH81910032 U-PACKING SEAL SEAT
33	PH81910033 PRESSURE ADJUSTING HANDLE COVER
34	PSB31M CAP SCREW M8-1.25 X 25
35	PN03M HEX NUT M8-1.25
36	PH81910036 PRESSURE ADJUSTING HANDLE
37	PH81910037 PRESSURE ADJUSTING SEAT
38	PH81910038 UPPER SPRING WASHER
39	PH81910039 PRESSURE ADJUSTING SPRING
40	PH81910040 LOWER SPRING WASHER
41	PH81910041 WATER RETURN VALVE ROD
42	PH81910042 VALVE JACKET INNER GASKET

REF PART #	DESCRIPTION
43	PH81910043 VALVE JACKET WATER RETURN
44	PH81910044 VALVE JACKET OUTER GASKET
45	PH81910045 WATER RETURN VALVE CORE
46	PH81910046 WATER RETURN VALVE SEAT
47	PH81910047 VALVE SEAT GASKET
48	PH81910048 OUTLET T CONNECTOR GASKET
49	PH81910049 WATER OUTLET T CONNECTOR
50	PH81910050 FIX BLOT GASKET
51	PH81910051 FIX BLOT OUTLET T CONNECTOR
52	PH81910052 FIX BLOT INLET T CONNECTOR
53	PH81910053 INLET T CONNECTOR GASGET SMALL
54	PH81910054 WATER INLET T CONNECTOR
55	PH81910055 TWO T CONNECTOR GASKET
56	PH81910056 INLET T CONNECTOR GASGET
57	PH81910057 WATER INLET CONNECTOR GASGET
58	PH81910058 WATER INLET CONNECTOR
59	PH81910059 3/8" QD BODY
60	PH81910060 DETERGENT INJECTOR
61	PH81910061 INJECTOR SPRING
62	PH81910062 INJECTOR BALL
63	PH81910063 INJECTION NOZZLE GASKET
64	PH81910064 INJECTION NOZZLE
65	PH81910065 WATER SHOOTING NOZZLE
66	PH81910066 WATER OUTLET JOINT
67	PH81910067 WATER OUTLET JOINT GASKET
68	PH81910068 WATER OUTLET CONE VALVE SPRING
69	PH81910069 WATER OUTLET CONE VALVE
70	PH81910070 WATER OUTLET CONE VALVE GASKET
71	PH81910071 CYLINDER
72	PH81910072 CHECK VALVE GASKET
73	PH81910073 WASHER CHECK VALVE
74	PH81910074 CHECK VALVE STOPPER
75	PH81910075 SPRING CHECK VALVE
76	PH81910076 CHECK VALVE BOX
77	PH81910077 COMPACTION GASKET
78	PH81910078 CHECK VALVE COMPACTION CAP
79	PH81910079 CAP SCREW M6-1 X 53
79-1	PLW03M LOCK WASHER 6MM
80	PSB31M CAP SCREW M8-1.25 X 25
81	PLW04M LOCK WASHER 8MM
82	PW01M FLAT WASHER 8MM



Engine Block Parts Breakdown

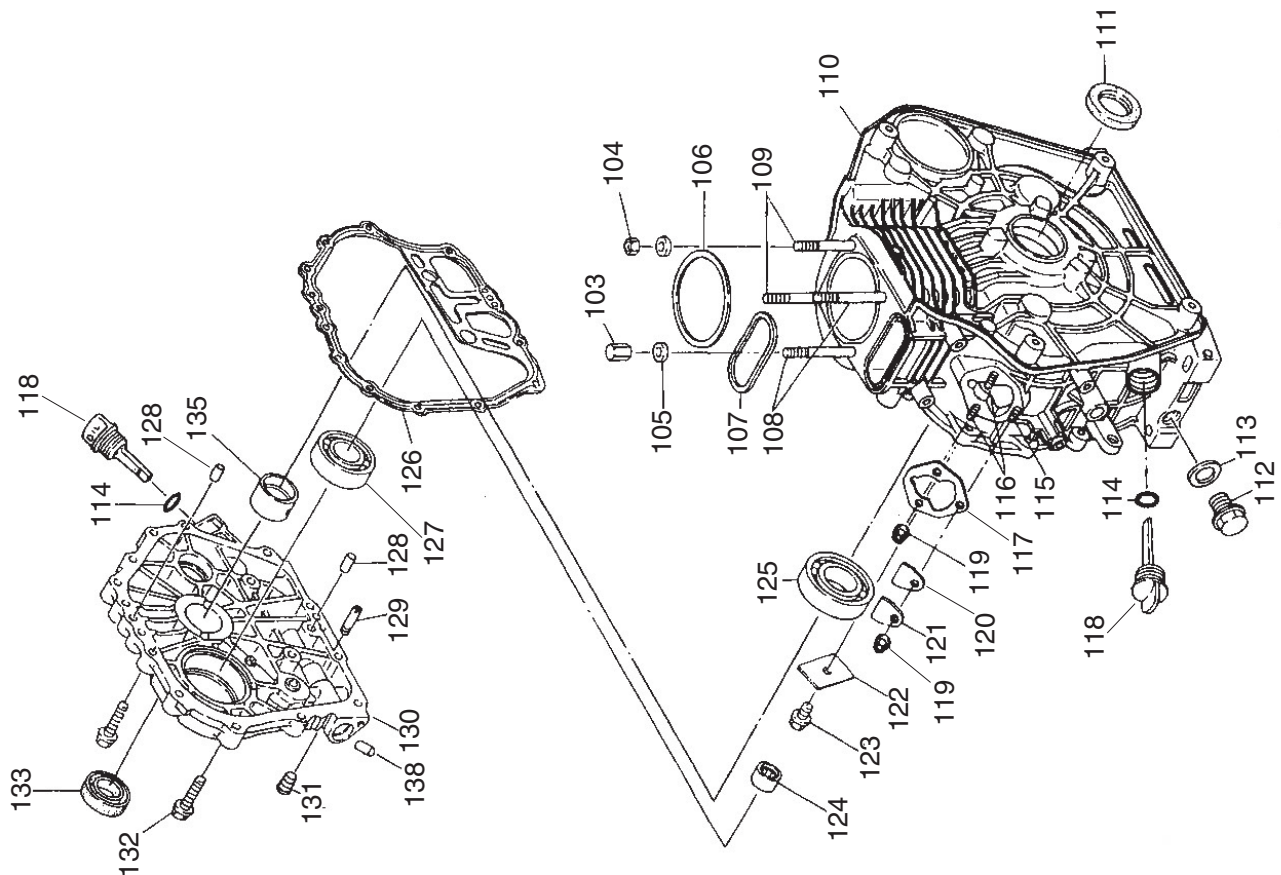

REF	PART #	DESCRIPTION
103	PH81910103	CYLINDER HEAD NUTS (LONG)
104	PH81910104	CYLINDER HEAD NUTS (SHORT)
105	PH81910105	CYLINDER HEAD NUT GASKET
106	PH81910106	CYLINDER HEAD GASKET
107	PH81910107	OVAL RING GASKET 5.1 X 2.6
108	PH81910108	CYLINDER HEAD BOLTS LONG
109	PH81910109	CYLINDER HEAD BOLTS SHORT
110	PH81910110	ENGINE BLOCK
111	PH81910111	REAR OIL SEAL 35 X 50 X 8
112	PH81910112	OIL DRAIN PLUG
113	PH81910113	OIL DRAIN PLUG GASKET
114	PH81910114	O-RING FOR OIL DIPSTICK
115	PH81910115	FUEL PUMP STUD
116	PH81910116	FUEL PUMP LONG STUD
117	PH81910117	FUEL INJECTOR GASKET
118	PH81910118	OIL DIPSTICK
119	PN01M	HEX NUT M6-1

REF	PART #	DESCRIPTION
120	PH81910120	SEALING PLATE GASKET
121	PH81910121	SEALING PLATE
122	PH81910122	THRUST PIECE
123	PH81910123	FLANGE FACE WITH BOLTS
124	PH81910124	NEEDLE BEARING
125	PH81910125	BALL BEARING
126	PH81910126	CRANKCASE COVER GASKET
127	PH81910127	BEARING 207
128	PH81910128	RETAINING PIN 8 X 12
129	PH81910129	FUEL PIPE
130	PH81910130	CRANKCASE COVER
131	PH81910131	INNER HEXAGON PLUG G1/8
132	PH81910132	FLANGE BOLT M8-1.25 X 33.5
133	PH81910133	FRONT OIL SEAL 35 X 50 X 10
135	PH81910135	MAIN BUSHING
138	PH81910138	ALUMINUM PLUG DIAMETER 8 X 8



Engine Cylinder Head Parts Breakdown

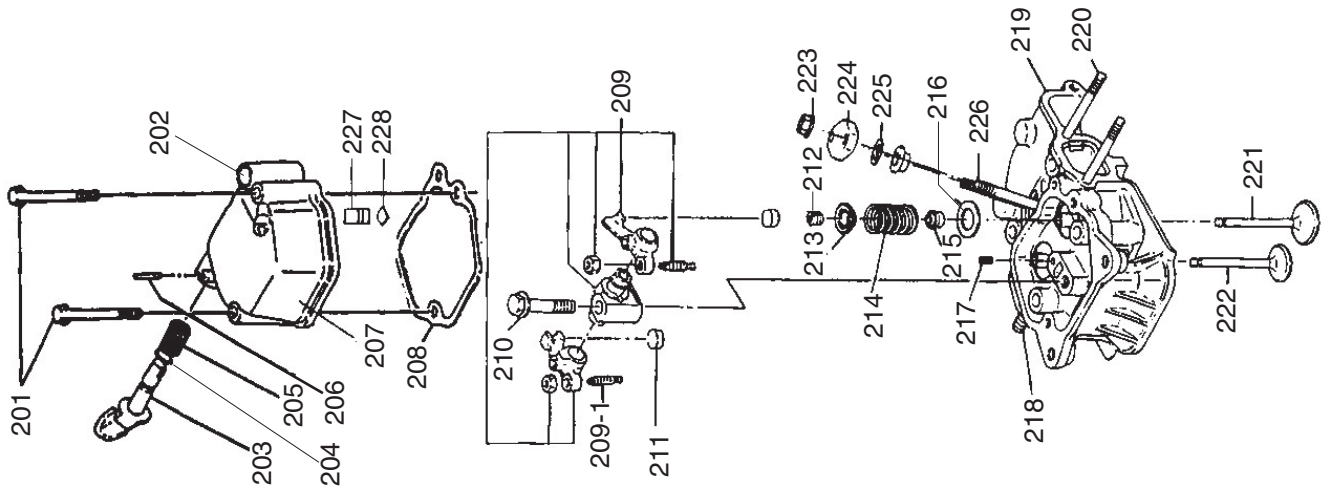

REF	PART #	DESCRIPTION
201	PH81910201	FLANGE BOLT M6-1 X 70
202	PH81910202	OIL HOLE PLUG
203	PH81910203	DECOMPRESSION SHAFT
204	PH81910204	O-RING 10 X 1.9
205	PH81910205	TORSION SPRING
206	PH81910206	RETAINING PIN 3 X 16
207	PH81910207	CYLINDER HEAD COVER
208	PH81910208	CYLINDER HEAD COVER GASKET
209	PH81910209	ROCKER ARM
209-1	PH81910209-1	VALVE ADJUSTING SCREW
210	PH81910210	ROCKER SHAFT FASTENING BOLT
211	PH81910211	ADJUSTING VALVE SPACER
212	PH81910212	VALVE CLIP
213	PH81910213	VALVE SPRING SEAT
214	PH81910214	VALVE SPRING

REF	PART #	DESCRIPTION
215	PH81910215	VALVE GUIDE OIL SEAL
216	PH81910216	VALVE SPRING WASHER
217	PH81910217	PIN 4 X 8
218	PH81910218	DOUBLE ENDED STUD
219	PH81910219	CYLINDER HEAD
220	PH81910220	DOUBLE ENDED BOLT
221	PH81910221	INTAKE VALVE
222	PH81910222	EXHAUST VALVE
223	PN01M	HEX NUT M6-1
224	PH81910224	FUEL INJECTOR PRESSURE PLATE
225	PH81910225	FUEL INJECTOR GASKET
226	PH81910226	FUEL INJECTOR BOLT (LONG)
227	PH81910227	BREATHER ASSEMBLY
228	PH81910228	O-RING 12 X 1.9



Engine Piston and Crank Parts Breakdown

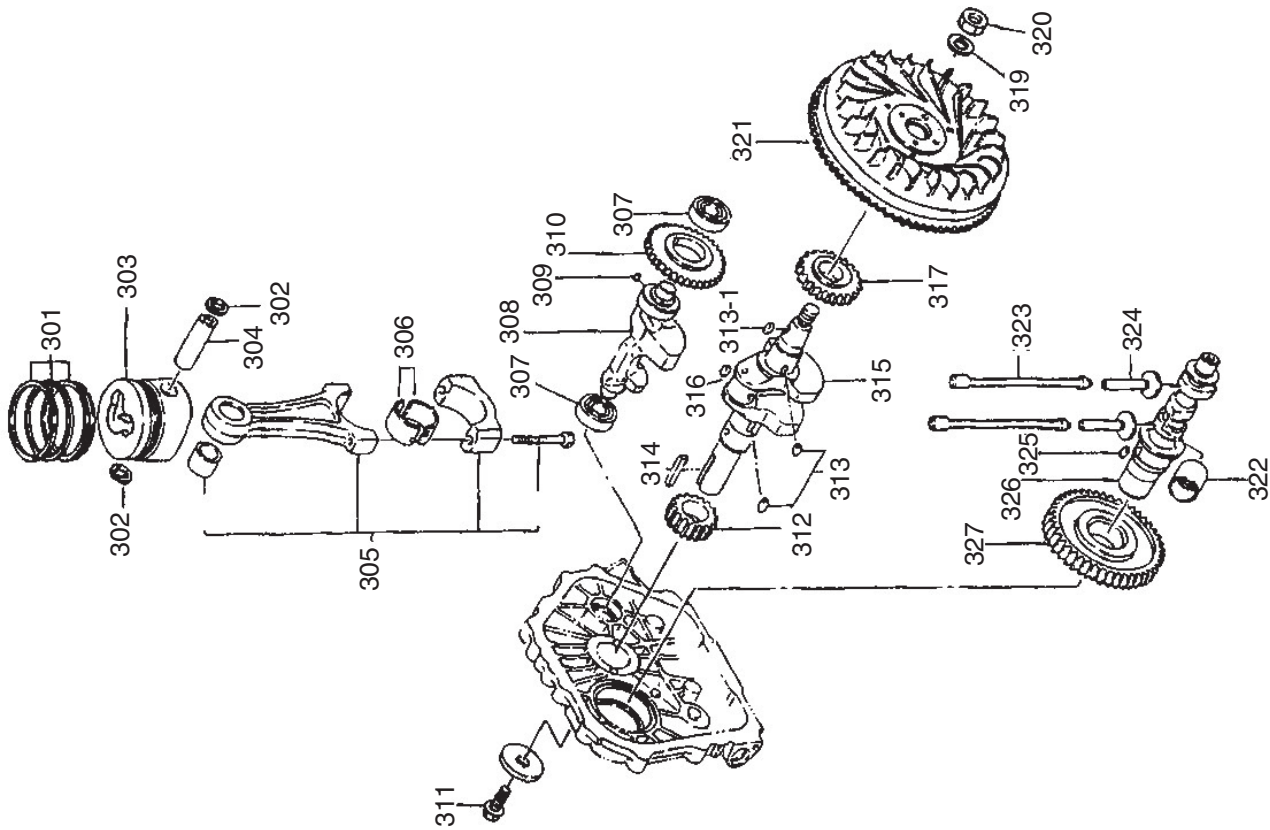

REF	PART #	DESCRIPTION
301	PH81910301	PISTON RINGS
302	PH81910302	PISTON PIN RETAINER CLIP 23MM
303	PH81910303	PISTON
304	PH81910304	WRIST PIN
305	PH81910305	CONNECTING ROD ASSEMBLY
306	PH81910306	CONNECTING ROD BEARING
307	PH81910307	BEARING
308	PH81910308	BALANCING SHAFT
309	PH81910309	KEY 5 X 7
310	PH81910310	BALANCING SHAFT TIMING GEAR
311	PH81910311	FLANGE BOLT
312	PH81910312	CRANKSHAFT TIMING GEAR
313	PH81910313	KEY 5 X 12
313-1	PH81910313-1	KEY 5 X 14

REF	PART #	DESCRIPTION
314	PH81910314	KEY 6 X 63
315	PH81910315	CRANKSHAFT
316	PH81910316	PLUG 6 X 8
317	PH81910317	BALANCING SHAFT DRIVING GEAR
319	PH81910319	FLYWHEEL NUT GASKET
320	PH81910320	FLYWHEEL NUT
321	PH81910321	FLYWHEEL WITH RING GEAR
322	PH81910322	FUEL PUMP ROD SLEEVE
323	PH81910323	PUSH ROD
324	PH81910324	TAPPET
325	PH81910325	KEY 5 X 14
326	PH81910326	CAMSHAFT
327	PH81910327	CAMSHAFT TIMING GEAR



Engine Fuel Tank Parts Breakdown

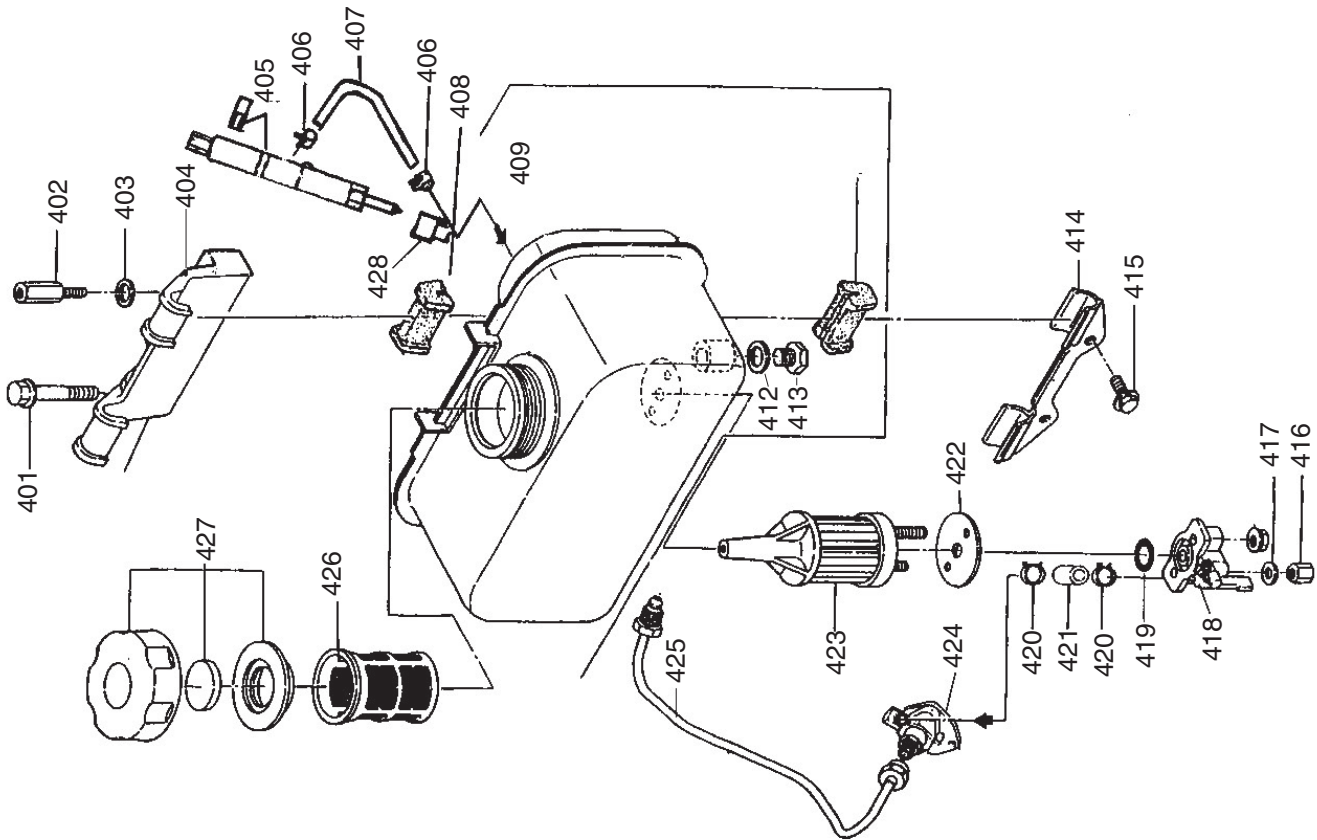

REF	PART #	DESCRIPTION
401	PH81910401	FLANGE BOLT M8-1.25 X 45
402	PH81910402	UPPER BRACKET FASTENER
403	PW01M	FLAT WASHER 8MM
404	PH81910404	UPPER TANK BRACKET
405	PH81910405	INJECTOR
406	PH81910406	HOSE CLAMP
407	PH81910407	FUEL HOSE
408	PH81910408	RUBBER FUEL TANK MOUNT
409	PH81910409	FUEL TANK
412	PH81910412	FUEL DRAIN GASKET
413	PH81910413	FUEL DRAIN PLUG
414	PH81910414	LOWER TANK BRACKET
415	PH81910415	FLANGE BOLT M6-1 X 14

REF	PART #	DESCRIPTION
416	PH81910416	HEX NUT M6-1
417	PW03M	FLAT WASHER 6MM
418	PH81910418	FUEL TANK PETCOCK ASSEMBLY
419	PH81910419	FLAT WASHER
420	PH81910420	FUEL PIPE CLAMP
421	PH81910421	FUEL HOSE
422	PH81910422	FUEL FILTER GASKET
423	PH81910423	FUEL FILTER ASSEMBLY
424	PH81910424	FUEL INJECTION PUMP
425	PH81910425	HIGH PRESSURE FUEL PIPE
426	PH81910426	FUEL CUP FILTER
427	PH81910427	FUEL CAP ASSEMBLY
428	PH81910428	FUEL INJECTOR CAP



Engine Lubrication/Speed Parts Breakdown

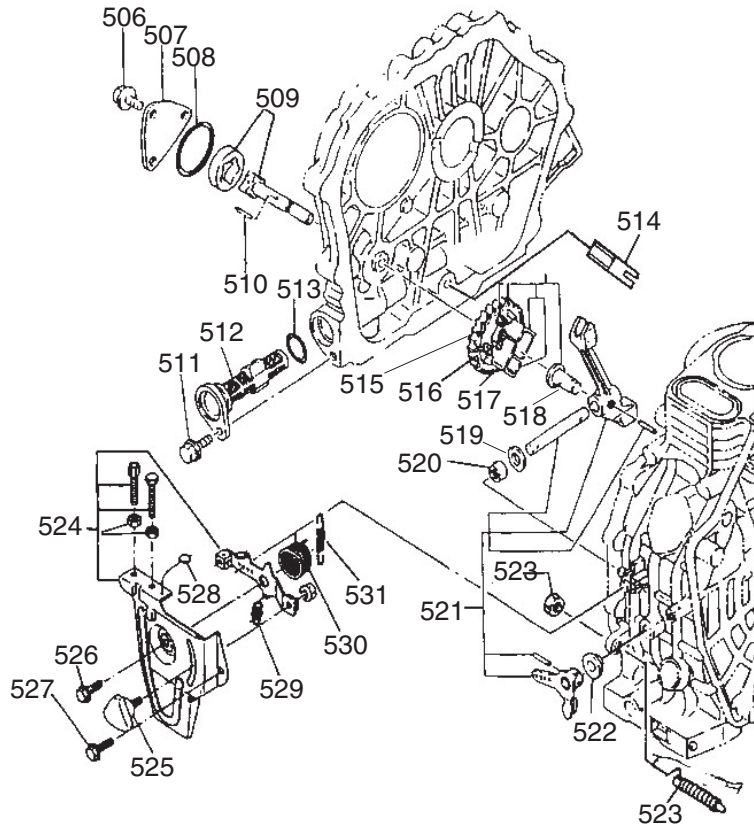

REF	PART #	DESCRIPTION
506	PFB01M	FLANGE BOLT M6-1 X 12
507	PH81910507	OIL PUMP COVER
508	PH81910508	O-RING 34.5 X 1.8
509	PH81910509	OIP PUMP ASSEMBLY
510	PH81910510	PIN 3 X 6
511	PH81910511	FLANGE BOLT M9 X 14
512	PH81910512	OIL FILTER CLEANING ELEMENT
513	PH81910513	SEALING RING 20 X 2.65
514	PH81910514	OIL GUIDE
515	PH81910515	OIL PUMP DRIVING GEAR
516	PH81910516	FLY BLOCK PIN
517	PH81910517	FLY BLOCK
518	PH81910518	GOVERNOR FORK TAPPET

REF	PART #	DESCRIPTION
519	PH81910519	LEVER SHAFT GASKET
520	PH81910520	BEARING
521	PH81910521	FORK LEVER ASSEMBLY
522	PH81910522	WASHER
523	PH81910523	FUEL CONTROLLER PARTS
524	PH81910524	HANDLE BRACKET ASSEMBLY
525	PH81910525	SPEED CONTROL LEVER
526	PH81910526	FLANGE BOLT M6-1 X 14
527	PH81910527	FLANGE BOLT M6-1 X 18
528	PH81910528	LEAD SEAL
529	PH81910529	RETURN SPRING 2
530	PH81910530	RETURN SPRING 1
531	PH81910531	SPEED CONTROL SPRING



Engine Recoil Starter Parts Breakdown

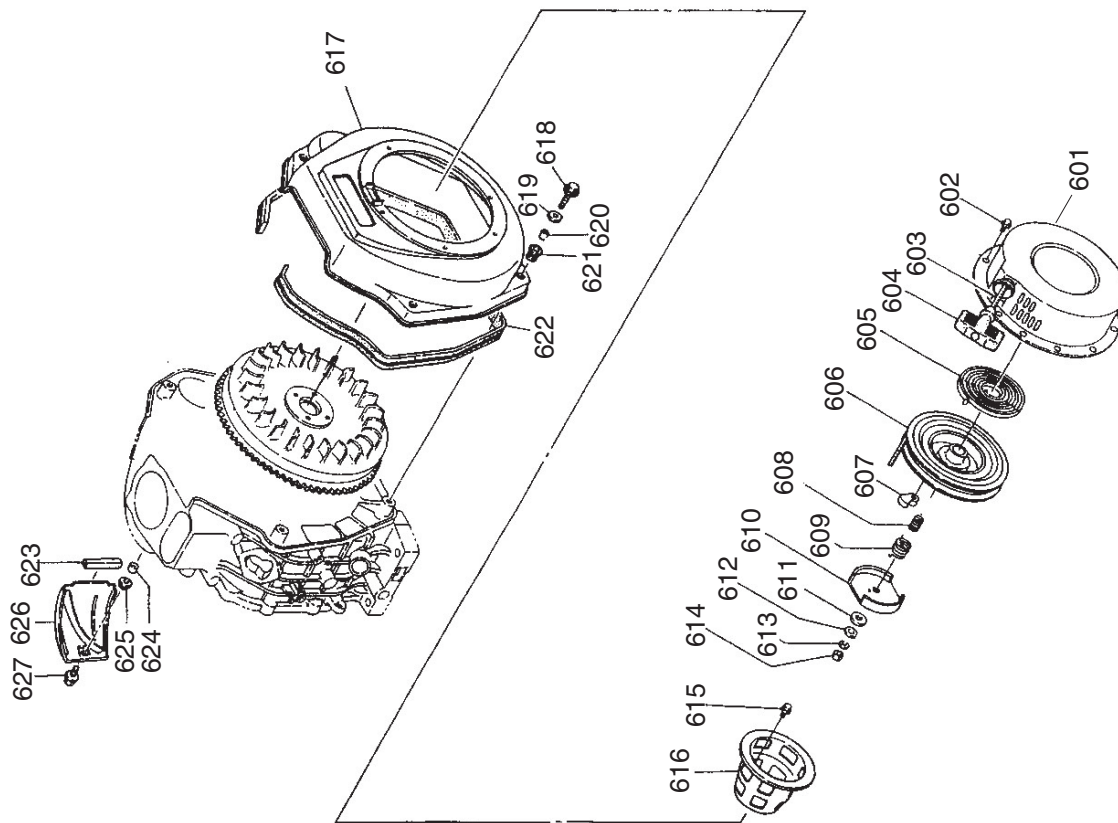

REF	PART #	DESCRIPTION
601	PH81910601	RECOIL CASE ASSEMBLY
602	PH81910602	FLANGE BOLT M6-1 X 8
603	PH81910603	RECOIL STARTER ROPE
604	PH81910604	RECOIL STARTER HANDLE
605	PH81910605	FLAT TORSIONAL SPRING
606	PH81910606	RECOIL REEL
607	PH81910607	STARTING CLAW
608	PH81910608	HELICAL SPRING
609	PH81910609	TORSIONAL SPRING
610	PH81910610	STARTING CLAW PLATE
611	PH81910611	FRICTION PLATE
612	PH81910612	FRICTION PLATE GASKET
613	PH81910613	SPRING WASHER
614	PN01M	HEX NUT M6-1

REF	PART #	DESCRIPTION
615	PFB01M	FLANGE BOLT M6-1 X 12
616	PH81910616	STARTER
617	PH81910617	RECOIL STARTER COVER
618	PH81910618	FLANGE BOLT M6-1 X 22
619	PW03M	FLAT WASHER 6MM
620	PH81910620	COLLAR
621	PH81910621	SHOCK ABSORBER
622	PH81910622	SHOCK PADS
623	PH81910623	SHOCK ISOLATOR
624	PH81910624	COLLAR
625	PH81910625	PAD
626	PH81910626	WIND LEADING PLATE
627	PH81910627	FLANGE BOLT M6-1 X 22



Engine Air Filter, Muffler, and Fuel Pump Parts Breakdown

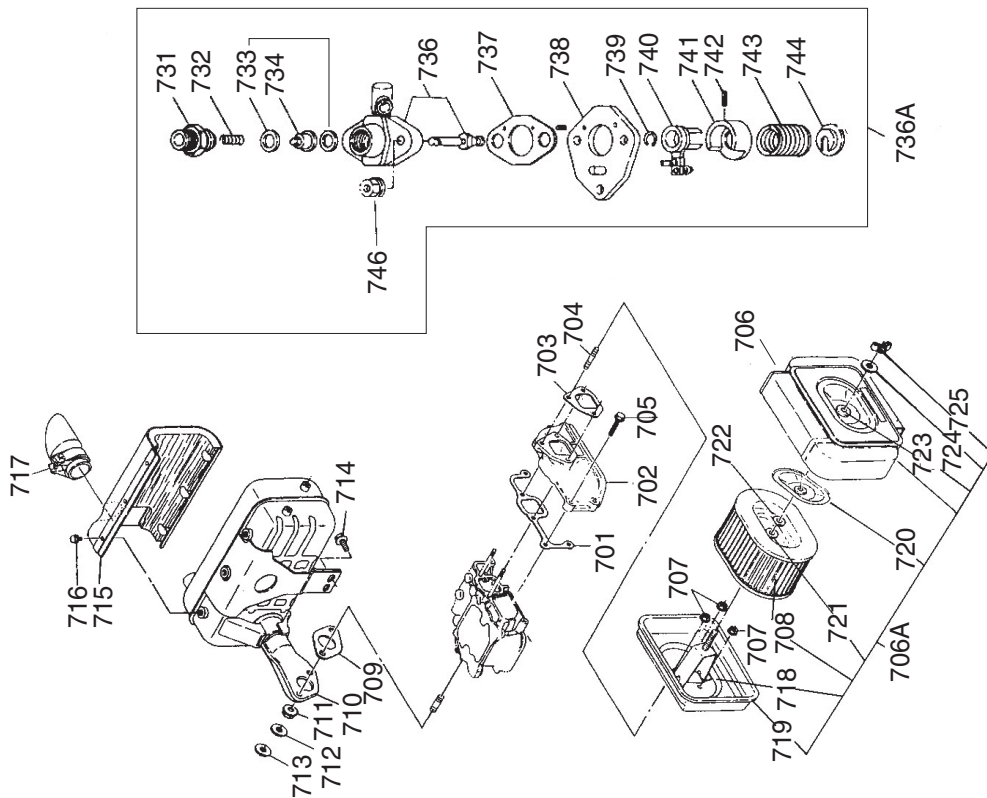

REF	PART #	DESCRIPTION
701	PH81910701	INTAKE PIPE GASKET
702	PH81910702	INTAKE PIPE
703	PH81910703	AIR CLEANER GASKET
704	PH81910704	EXHAUST MANIFOLD STUD
705	PH81910705	FLANGE BOLT M6-1 X 22
706A	PH81910706A	AIR FILTER TOP ASSEMBLY
706	PH81910706	AIR FILTER ASSEMBLY
707	PH81910707	HEX NUT M6-1
708	PH81910708	AIR FILTER ELEMENT
709	PH81910709	MUFFLER GASKET
710	PH81910710	MUFFLER ASSEMBLY
711	PW01M	FLAT WASHER 8MM
712	PLW04M	LOCK WASHER 8MM
713	PH81910713	HEX NUT M6-1
714	PH81910714	FLANGE BOLT M8-1.25 X 14
715	PH81910715	MUFFLER SCREAM COVER
716	PH81910716	FLANGE BOLT M6-1 X 14
717	PH81910717	MUFFLER TAIL PIPE
718	PH81910718	INNER SHOCK SEALING RING
719	PH81910719	AIR FILTER BOTTOM ASSEMBLY
720	PH81910720	OUTER SHOCK SEALING RING

REF	PART #	DESCRIPTION
721	PH81910721	AIR FILTER SHOCK ABSORBER
722	PH81910722	COLLAR
723	PH81910723	AIR FILTER SHOCK ABSORBER
724	PH81910724	COLLAR
725	PWN02M	WING NUT M8-1.25
731	PH81910731	DELIVERY HOLDER
732	PH81910732	DELIVERY SPRING
733	PH81910733	DELIVERY GASKET
734	PH81910734	DELIVERY VALVE
736A	PH81910736A	FUEL PUMP ASSEMBLY
736	PH81910736	PLUNGER ASSEMBLY
737	PH81910737	ADJUSTING GASKET
738	PH81910738	PUMP BODY CONNECTING PLATE
739	PH81910739	CIRCLIP
740	PH81910740	CONTROL LEVER ASSEMBLY
741	PH81910741	SPRING SEAT
742	PH81910742	SLEEVE PIN
743	PH81910743	FUEL INJECTION PUMP
744	PH81910744	FUEL INJECTION PUMP SPRING
746	PN01M	HEX NUT M6-1



Engine Electric Start Parts Breakdown

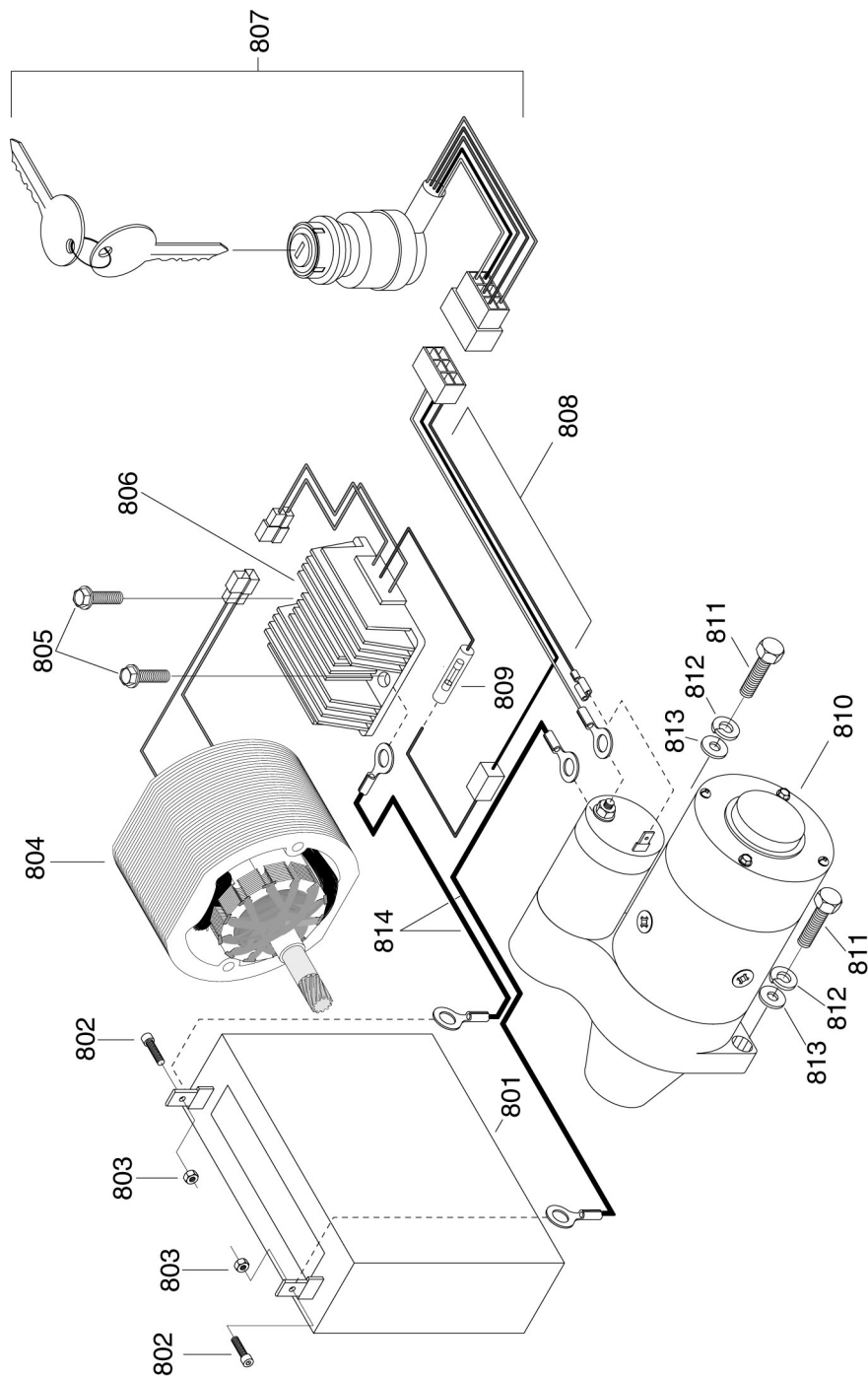

REF	PART #	DESCRIPTION
801	PH81910801	BATTERY
802	PH81910802	CAP SCREW M5-0.8 X 13
803	PN06M	HEX NUT M5-.8
804	PH81910804	ALTERNATOR ASSEMBLY
805	PFB01M	FLANGE BOLT M6-1 X 12
806	PH81910806	VOLTAGE REGULATOR
807	PH81910807	KEY AND SWITCH ASSEMBLY

REF	PART #	DESCRIPTION
808	PH81910808	WIRING HARNESS
809	PH81910809	FUSE
810	PH81910810	STARTER MOTOR
811	PB14M	HEX BOLT M10-1.5 X 35
812	PLW06M	LOCK WASHER 10MM
813	PW04M	FLAT WASHER 10MM
814	PH81910814	BATTERY CABLE



Frame and Hardware Parts Breakdown

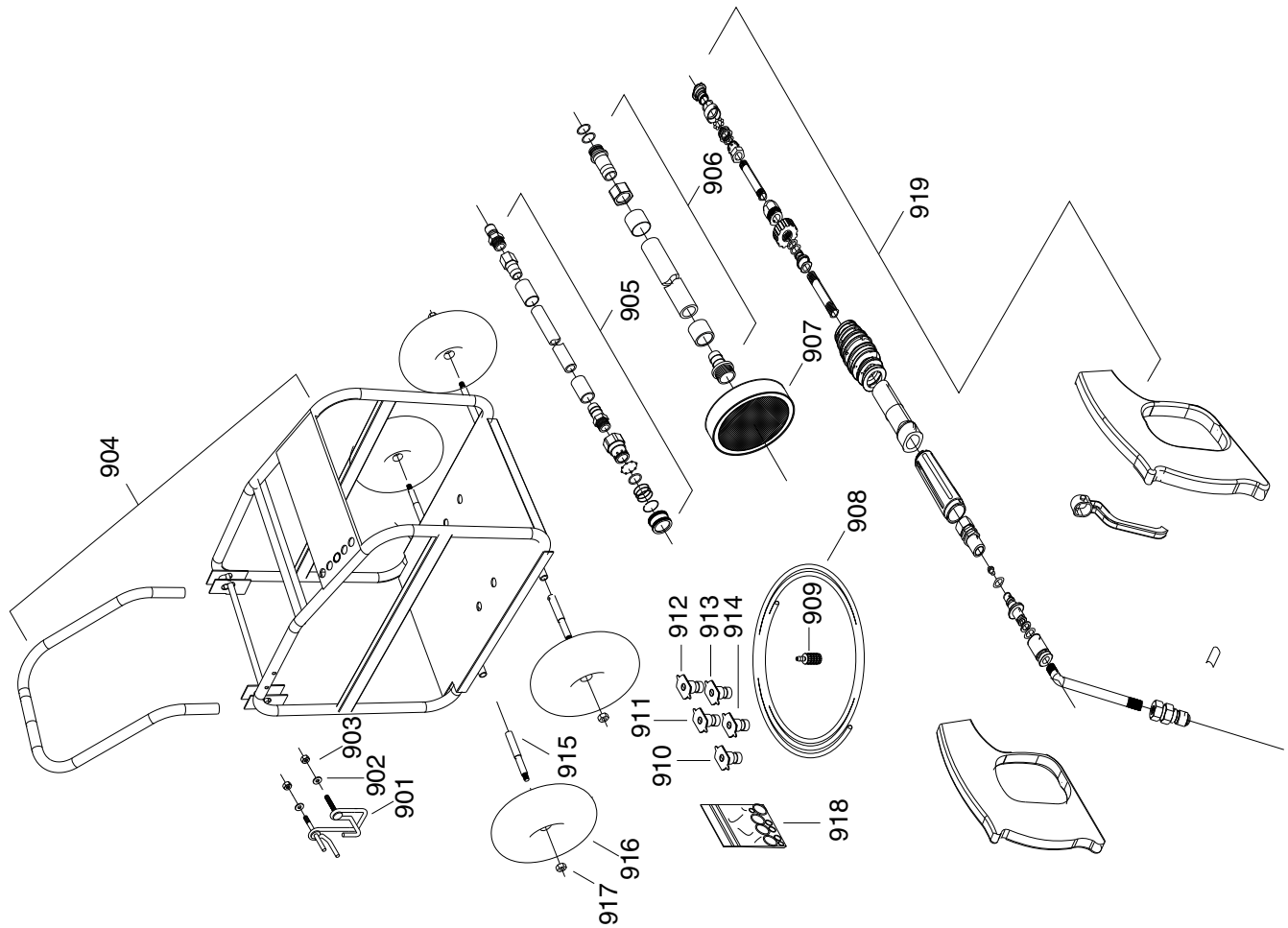

REF	PART #	DESCRIPTION
901	PH81910901	SPRAY GUN BRACKET
902	PW01M	FLAT WASHER 8MM
903	PN03M	HEX NUT M8-1.25
904	PH81910904	FRAME ASSEMBLY
905	PH81910905	HIGH PRESSURE HOSE ASSEMBLY
906	PH81910906	IN-FEED HOSE ASSEMBLY
907	PH81910907	IN-FEED FILTER
908	PH81910908	CHEMICAL HOSE
909	PH81910909	CHEMICAL FILTER
910	PH81910910	0 DEGREE NOZZLE

REF	PART #	DESCRIPTION
911	PH81910911	15 DEGREE NOZZLE
912	PH81910912	25 DEGREE NOZZLE
913	PH81910913	40 DEGREE NOZZLE
914	PH81910914	CHEMICAL NOZZLE
915	PH81910915	AXLE
916	PH81910916	WHEEL ASSEMBLY
917	PLN09M	LOCK NUT M12-1.75
918	PH81910918	O-RING KIT
919	PH81910919	SPRAY GUN AND WAND ASSEMBLY



Machine Labels Breakdown

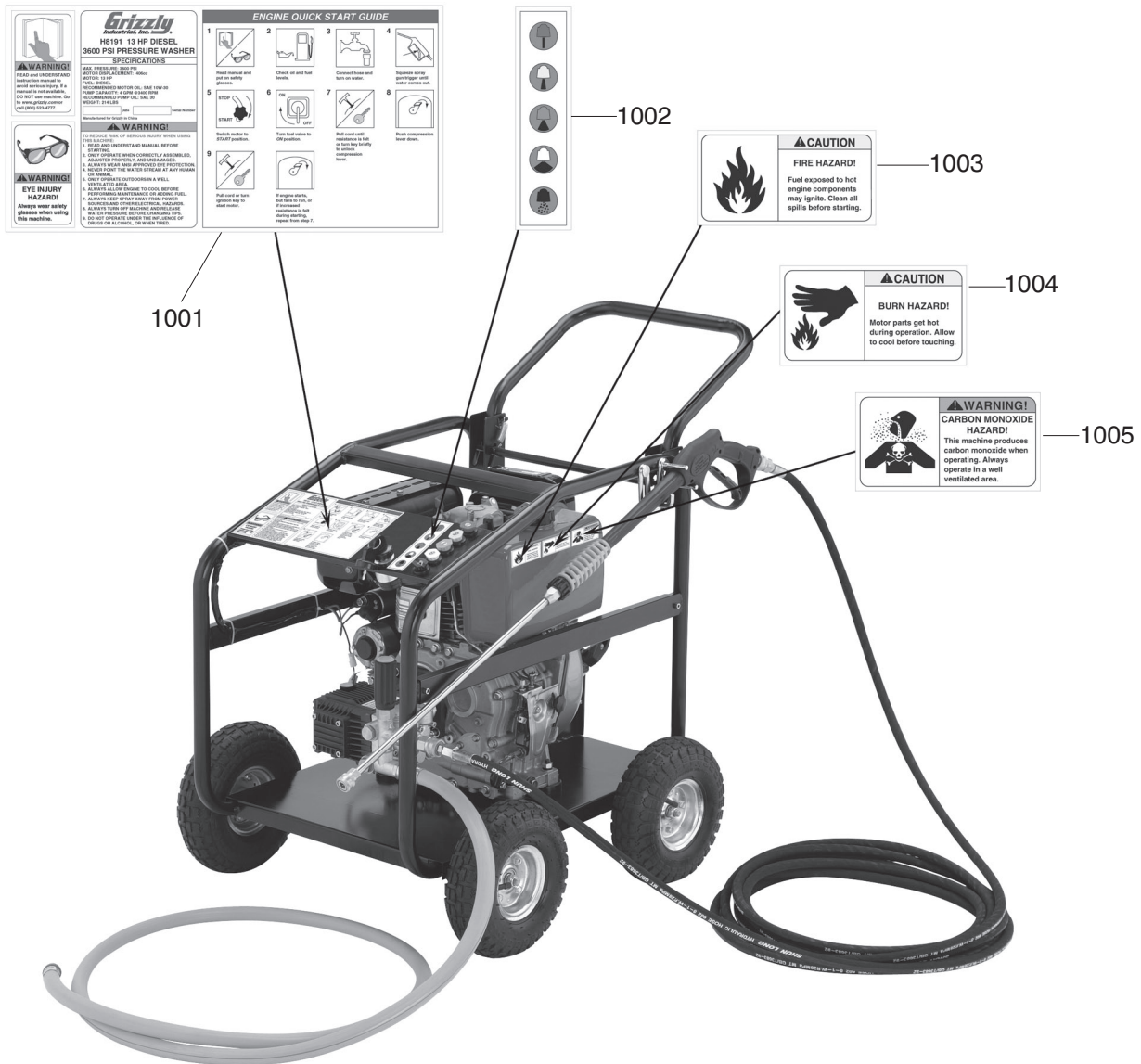

REF	PART #	DESCRIPTION
1001	PH81911001	MACHINE ID LABEL
1002	PH81911002	NOZZLE COLOR CHART LABEL
1003	PH81911003	FLAMABLE WARNING LABEL

REF	PART #	DESCRIPTION
1004	PH81911004	HOT SURFACES WARNING LABEL
1005	PH81911005	CARBON MONOXIDE WARNING LABEL

WARNING

Safety labels warn about machine hazards and ways to prevent injury. The owner of this machine **MUST** maintain the original location and readability of the labels on the machine. If any label is removed or becomes unreadable, **REPLACE** that label before using the machine again. Contact Grizzly at (800) 523-4777 or www.grizzly.com to order new labels.





WARRANTY CARD

Name _____

Street _____

City _____ State _____ Zip _____

Phone # _____ Email _____ Invoice # _____

Model # _____ Order # _____ Serial # _____

The following information is given on a voluntary basis. It will be used for marketing purposes to help us develop better products and services. **Of course, all information is strictly confidential.**

1. How did you learn about us?

- Advertisement
- Card Deck
- Friend
- Website
- Catalog
- Other:

2. Which of the following magazines do you subscribe to?

- | | | |
|---|--|---|
| <input type="checkbox"/> Cabinet Maker | <input type="checkbox"/> Popular Mechanics | <input type="checkbox"/> Today's Homeowner |
| <input type="checkbox"/> Family Handyman | <input type="checkbox"/> Popular Science | <input type="checkbox"/> Wood |
| <input type="checkbox"/> Hand Loader | <input type="checkbox"/> Popular Woodworking | <input type="checkbox"/> Wooden Boat |
| <input type="checkbox"/> Handy | <input type="checkbox"/> Practical Homeowner | <input type="checkbox"/> Woodshop News |
| <input type="checkbox"/> Home Shop Machinist | <input type="checkbox"/> Precision Shooter | <input type="checkbox"/> Woodsmith |
| <input type="checkbox"/> Journal of Light Cont. | <input type="checkbox"/> Projects in Metal | <input type="checkbox"/> Woodwork |
| <input type="checkbox"/> Live Steam | <input type="checkbox"/> RC Modeler | <input type="checkbox"/> Woodworker West |
| <input type="checkbox"/> Model Airplane News | <input type="checkbox"/> Rifle | <input type="checkbox"/> Woodworker's Journal |
| <input type="checkbox"/> Modeltec | <input type="checkbox"/> Shop Notes | <input type="checkbox"/> Other: |
| <input type="checkbox"/> Old House Journal | <input type="checkbox"/> Shotgun News | |

3. What is your annual household income?

- \$20,000-\$29,000
- \$30,000-\$39,000
- \$40,000-\$49,000
- \$50,000-\$59,000
- \$60,000-\$69,000
- \$70,000+

4. What is your age group?

- 20-29
- 30-39
- 40-49
- 50-59
- 60-69
- 70+

5. How long have you been a woodworker/metalworker?

- 0-2 Years
- 2-8 Years
- 8-20 Years
- 20+ Years

6. How many of your machines or tools are Grizzly?

- 0-2
- 3-5
- 6-9
- 10+

7. Do you think your machine represents a good value? Yes No

8. Would you recommend Grizzly Industrial to a friend? Yes No

9. Would you allow us to use your name as a reference for Grizzly customers in your area?
Note: We never use names more than 3 times. Yes No

10. Comments: _____

CUT ALONG DOTTED LINE

FOLD ALONG DOTTED LINE



Place Stamp Here



GRIZZLY INDUSTRIAL, INC.
P.O. BOX 2069
BELLINGHAM, WA 98227-2069



FOLD ALONG DOTTED LINE

Send a Grizzly Catalog to a friend:

Name _____
Street _____
City _____ State _____ Zip _____

TAPE ALONG EDGES--PLEASE DO NOT STAPLE

WARRANTY AND RETURNS

Grizzly Industrial, Inc. warrants every product it sells for a period of **1 year** to the original purchaser from the date of purchase. This warranty does not apply to defects due directly or indirectly to misuse, abuse, negligence, accidents, repairs or alterations or lack of maintenance. This is Grizzly's sole written warranty and any and all warranties that may be implied by law, including any merchantability or fitness, for any particular purpose, are hereby limited to the duration of this written warranty. We do not warrant or represent that the merchandise complies with the provisions of any law or acts unless the manufacturer so warrants. In no event shall Grizzly's liability under this warranty exceed the purchase price paid for the product and any legal actions brought against Grizzly shall be tried in the State of Washington, County of Whatcom.

We shall in no event be liable for death, injuries to persons or property or for incidental, contingent, special, or consequential damages arising from the use of our products.

To take advantage of this warranty, contact us by mail or phone and give us all the details. We will then issue you a "Return Number," which must be clearly posted on the outside as well as the inside of the carton. We will not accept any item back without this number. Proof of purchase must accompany the merchandise.

The manufacturers reserve the right to change specifications at any time because they constantly strive to achieve better quality equipment. We make every effort to ensure that our products meet high quality and durability standards and we hope you never need to use this warranty.

Please feel free to write or call us if you have any questions about the machine or the manual.

Thank you again for your business and continued support. We hope to serve you again soon.

grizzly.com

TOOL WEBSITE

Buy Direct and Save with Grizzly® – Trusted, Proven and a Great Value!

*Visit Our Website Today And Discover
Why Grizzly® Is The Industry Leader!*

- SECURE ORDERING
- ORDERS SHIPPED WITHIN 24 HOURS
- E-MAIL RESPONSE WITHIN ONE HOUR

-OR-

Call Today For A **FREE**
Full Color Catalog

1-800-523-4777

